

Standard Operation Procedures for Ozone using the Thermo 49i

In Use By

**Polk County Air Quality
Ambient Air Monitoring Personnel**

For Calendar Year 2023

Revised: February 17, 2023

**Section: 1
Revision: 27**

PREPARED BY



Polk County Air Quality Air Pollution Monitoring Specialist

3/2/23
Date

SIGNATURES/APPROVALS



Polk County Air Quality Assurance Officer

3/2/23
Date

POLK COUNTY AIR QUALITY DIVISION

STANDARD OPERATING PROCEDURE MANUAL FOR THERMO ENVIRONMENTAL (49i) OZONE (O_3) MONITORING

Table of Contents	Page #
1.1. Purpose.....	3
1.2. Scope.....	3
1.3. References.....	3
1.4. Introduction	4
1.5. Sampler Setup	5
1.5.1 Health And Safety	5
1.5.2 Site Selection.....	5
1.5.2.1 The Monitoring Station.....	5
1.5.2.2 Probe Placement.....	6
1.5.3 Inspecting New Equipment.....	6
1.5.4 Equipment Installation.....	6
1.5.5 Programming Equipment.....	7
1.5.5.1 Range and Units.....	7
1.5.5.2 Averaging Time.....	7
1.5.5.3 Temperature Compensation.....	7
1.5.5.4 Pressure Compensation.....	8
1.5.5.5 Baud Rate.....	8
1.5.5.6 Clock Set.....	8
1.6. Standards.....	8
1.6.1 Local Primary Standards	9
1.6.2 Transfer Standards	10
1.6.3 Audit Standards.....	11
1.7 Qualification, Certification and Recertification	11
1.8 Calibrations.....	13
1.9 Quality Control	14
1.9.1 Station Inspection	14
1.9.2 Station Log Book	15
1.9.3 Bi-Weekly Zero, Precision and Span Checks.....	15
1.9.4 Agreement Between Collocated Monitors	16
1.9.5 Data Quality Objectives	16
1.9.6 Data Acquisition and Telemetry.....	17
1.10 Equipment, Maintenance and Trouble Isolation.....	17
1.10.1 Preventative Maintenance	17
1.10.1.1 Replace Ozone Scrubber.....	17
1.10.1.2 Sample Frequency Adjustment.....	17
1.10.1.3 Automatic Temperature and Pressure Compensation.....	18
1.10.1.4 Analyzer Leak Check.....	18
1.10.1.5 Sample Line Leak Check.....	18
1.10.1.6 Pressure Check (psi) Flow Rate.....	18
1.10.1.7 Solenoid Leak Check	19
1.10.1.8 Particulate Filter Changes	19
1.10.1.9 Replacing the Sample Lines	19
1.10.2 Trouble Isolation.....	19
1.10.3 Environmental Control for Monitoring Equipment.....	20
1.11 Quality Assurance (Accuracy Audits).....	20
1.11.1 Direct Comparison Audits.....	20
1.11.2 Audit Sequence.....	20
1.11.3 Federal Audits.....	21
1.12 Data Quality Assessment	22
1.12.1 Precision	22
1.12.2 Accuracy	22
1.12.3 Data Completeness	22
1.13 Procedures for Bi-Weekly Checks.....	22

1.13.1	Maintenance Mode for Agilaire Data Loggers.....	23
1.13.2	Remote Mode.....	23
1.13.3	Maintenance and Diagnostics Check.....	23
1.13.4	Zero, Precision and Span Checks	24
	1.13.4.1 Span Check	24
	1.13.4.2 Precision Check	25
	1.13.4.3 Zero Air Check.....	25
	1.13.4.4 Invalidate Data and Recalibrate.....	26
1.14	Automated Zero/Precision/Span Checks.....	26
1.14.1	Plumbing the System.....	27
1.14.2	Solenoid System.....	27
1.14.3	Calibration Program in the 49i Transfer Standard.....	27
	1.14.3.1 Next Time.....	27
	1.14.3.2 Period Hours.....	27
	1.14.3.3 Zero/Precision/Span Duration.....	28
	1.14.3.4 Zero/Span Averaging Time.....	28
1.14.4	Communication Settings in Agilaire AirVision Software.....	28
1.14.5	Calibration Program in AirVision.....	28

FIGURES

Figure 1-1:	Typical Calibration Setup of an Ozone Transfer/Audit Standard.....	10
Figure 1-2:	Typical Setup of a Direct Comparison Audit.....	21
Figure 1-3:	Thermo Scientific 49i Analyzer	23

TABLES

Table 1-1:	Measurement Quality Objectives.....	30
------------	-------------------------------------	----

Appendix A-	Forms and Field Sheets.....	33
Appendix B-	Instructions for Using the Ozone Primary Standard Certification Worksheet.....	46
Appendix C-	Instructions for Using 1x6 Averages Worksheet for Certification of Ozone Transfer Standards...	51
Appendix D-	EPA Memo on Addition of a Nafion Dryer to UV Analyzers.....	53
Polk County	Document Change Log.....	56

1.0 STANDARD OPERATING PROCEDURE FOR OZONE (O_3) MONITORING

1.1 Purpose

To establish a standard operating procedure (SOP) manual for the Polk County Air Quality Division personnel concerning the setup, operation, zero, precision and span checks, calibrations, audits and maintenance of ozone monitors maintained and operated by Polk County staff. This SOP is intended for individuals responsible for collecting ambient air monitoring data supported by the Polk County Air Quality Division.

The U.S. Environmental Protection Agency (EPA) has determined ground level ozone is a health and environmental concern. For this reason, National Ambient Air Quality Standards (NAAQS) have been established for ozone. As a result, an air monitoring network to monitor for ground level ozone was established in the Des Moines Metropolitan Statistical Area (MSA) and is maintained by Polk County Air Quality Division, Iowa.

The EPA has provided a memorandum indicating that a Nafion Dryer may be added to the 49iQ monitor installation that will partially dehumidify the sample air in an effort to mitigate monitor “noisiness” at times when the humidity is high. Polk County Air Quality will equip sampling sties with the Nafion humidity control system. The EPA memo can be found in Appendix D.

1.2 Scope

These procedures are to be used by Polk County Air Quality Division personnel. The objective of this SOP is to familiarize the station operator with procedures used in the collection of air monitoring data. The accuracy of data obtained from any instrument depends upon the instrument's performance and the operator's skill. It is important that the station operator become familiar with both this SOP as well as the manufacturer's instruction manual in order to achieve a high level of data quality. This SOP is to be used as an outline and is not intended to replace the equipment manufacturer's manual or procedures. This SOP describes the proper procedures for the setup, operation, zero, precision and span checks, calibrations, audits and maintenance of ozone equipment operated by Polk County Air Quality personnel.

1.3 References

- 1.3.1 Model 49i, UV Photometric Ozone Analyzer, Instruction Manual. Part Number 102434-00, November 30, 2006.**
- 1.3.2 EPA-454/B-13-004-Technical Assistance Document, October, 2013. Transfer Standards for the Calibration of Ambient Air Monitoring Analyzers for Ozone.**
- 1.3.3 EPA-600/4-79-057, September 1979. Technical Assistance Document for the Calibration of Ambient Ozone Monitors.**
- 1.3.4 EPA-454/B-17-001, January, 2017. Quality Assurance Handbook for Air Pollution Measurement Systems, Volume II, Ambient Air Quality Monitoring Program.**
- 1.3.5 Quality Assurance Handbook for Air Pollution Measurement Systems, Volume II, Ambient Air Quality Monitoring Program, Appendix D. Revision 1, March, 2017.**
- 1.3.6 40 Code of Federal Regulations (CFR) Part 50, Appendix D. Measurement Principle and Calibration Procedure for the Measurement of Ozone in the Atmosphere.**
- 1.3.7 40 Code of Federal Regulations (CFR) Part 58, Appendix A. Quality Assurance Requirements for State and Local Air Monitoring Stations (Slams).**

- 1.3.8 40 Code of Federal Regulations (CFR) Part 58, Appendix D. Network Design for State and Local Air Monitoring Stations (SLAMS), National Air Monitoring Stations (NAMS), and Photochemical Assessment Monitoring Stations (PAMS).**
- 1.3.9 Determination of Ozone by Ultraviolet Analysis, A New Method for Volume II, Ambient Air Specific Methods, Quality Assurance Handbook for Air Pollution Measurement Systems, Final Draft, May 1, 1997.**

1.4 Introduction

Ozone is a unique pollutant in that it is exclusively a secondary pollutant. This means that it is formed through a complex series of chemical reactions initiated by the release of a primary pollutant such as gasoline vapors. When a volatile organic compound, such as the VOC's in gasoline vapors, reacts with nitrogen dioxide (NO₂) in the presence of sunlight, OZONE is formed. Therefore the level or concentration of ozone formed is influenced by many factors, including concentrations of NO₂ and VOC's in the area, the intensity of the sun and local weather conditions. Ozone is a colorless and odorless gas that can have adverse health effects.

The 1990 National Ambient Air Quality Standards (NAAQS) revisions recognized ozone as a potential health hazard and therefore set limits on the concentrations permissible in the atmosphere.

Measurements of ozone in ambient air are based on the principle that ozone (O₃) molecules absorb UV light at a wavelength of 254nm. The degree to which the UV light is absorbed is directly related to the ozone concentration as described by the Beer-Lambert Law:

$$\frac{I}{I_0} = e^{-KLC}$$

Where:

K = molecular absorption coefficient, 308 cm⁻¹ (at 0° C and 1 atm)

L = length of cell, 38 cm

C = ozone concentration in parts per million (ppm)

I = UV light intensity of sample with ozone (sample gas)

I₀ = UV light intensity of sample without ozone (reference gas)

Ambient air is drawn into the ozone sample inlet, and split into two gas streams. One gas stream flows through an ozone scrubber to become the reference gas (I₀). The reference gas then flows to the reference solenoid valve. The sample gas (I) flows directly to the sample solenoid valve. The solenoid valves alternate the reference and sample gas streams between cells A and B every 10 seconds. When cell A contains reference gas, cell B contains sample gas and vice versa.

The UV light intensities of each cell are measured in detectors A and B. When the solenoid valves switch the reference sample gas streams to opposite cells, the light intensities are ignored for several seconds to allow the cells to be flushed. The ozone concentration is calculated for each cell and the average concentration is determined.

1.5 Sampler Setup

1.5.1 Health and Safety Warning/Precautions

Only properly trained personnel should perform 49i testing, installation, operation, maintenance and calibration procedures. As with all monitoring equipment, precautions should be taken when working around electricity, power tools and above ground elevations. Refer to the 49i manuals for specific safety precautions when performing specific maintenance or service procedures.

1.5.2 Site Selection

In selecting a location to measure for ozone, it is important to understand the relationship between ground level ozone, precursors of ozone (i.e. transportation and industrial sources), local meteorology and topography. Ozone is not emitted directly into the air, but is a result of a complex photochemical reaction involving organic compounds, oxides of nitrogen, and solar radiation. The worst ozone pollution episodes occur when a slow-moving, high-pressure system develops in the summer and the combination of hydrocarbons, high solar radiation and high air temperatures promote the formation of ozone. Since ozone levels are significantly lower during the fall and winter months, Polk County Air Quality is required by the EPA to monitor for ozone only during the "ozone season" (March through October). However, Polk County Air Quality will monitor for ozone year-round.

For more detailed information concerning site selection for ozone monitoring, refer to the 40 Code of Federal Regulations (CFR), Part 58, Appendix D, or the Quality Assurance Handbook for Air Pollution Measurement Systems, Volume II, Section 6.2, entitled "Monitoring Site Location."

1.5.2.1 The Monitoring Station

The structure housing the monitoring equipment may consist of a trailer, a room in a building, or a shelter designed specifically for air monitoring purposes. A clean, dry, secure and temperature controlled space is required so that the sampling equipment can operate properly.

Careful thought and planning is required in locating a monitoring station. The individual responsible for the installation must consider:

- Proximity to the nearest power source. A 120 VAC source is required for operation of the ozone monitoring instruments.
- The space where the equipment is housed must maintain a temperature range of 20-30°C. This usually requires the need for an air conditioner and a heater controlled by a thermostat.
- The accessibility of the equipment to the operator. The operator must be able to safely access the equipment during regular business hours.
- The security of the equipment. Monitoring instruments are expensive. They must be placed in a location where security can be assured.
- Contracts for rental of space or power. Contracts need to be signed with the owner of the property where the instruments are to be located.
- Ethernet lines for data transmission to a central computer.
- Local building codes. In most cases, the contractor installing the power, structure, concrete, etc. know the local building codes.

1.5.2.2 Probe Placement

Once the location of the station has been identified, the individual responsible for the installation must be familiar with the criteria for locating the probe. The location of the sample probe is critical and individuals performing the installation must follow specific guidelines involving:

- The distance of the probe inlet from nearby obstructions (buildings and trees)
- The vertical and horizontal distance of the probe inlet from the ground and support structure
- Air flow around the inlet of the probe
- The distance of the probe inlet from nearby roads

For specific information on monitoring site criteria refer to 40 Code of Federal Regulations, Part 58 (40 CFR 58).

1.5.3 Inspecting New Equipment

When shipment of the monitor is received, verify that the package contents are complete as ordered. Inspect the instrument for external physical damage due to shipping, such as scratched or dented panel surfaces and broken knobs or connectors.

Remove the instrument cover and all interior foam packing and save (in case future shipments of the instrumentation are needed). Make note of how the foam packing was installed.

Inspect the interior of the instrument for damage, such as broken components or loose circuit boards. Make sure that all of the circuit boards are completely secured. (Loose boards could short out the motherboard). If no damage is evident, the monitor is ready for calibration, installation and operation. If any damage due to shipping is observed contact Thermo Scientific at 1-866-282-0430 for instructions on how to proceed.

1.5.4 Equipment Installation

Installation of an ozone monitor consists of connecting the sample tubing to the sample gas inlet fitting and connecting the primary power and the data logger device. The sampler inlet line connection should be made with ¼ -inch outer diameter Teflon tubing.

Because the analyzer is an optical instrument, it is possible that particulate in the gas sample could interfere with the ozone readings, although the sampling/referencing cyclic operation of the instrument is designed to eliminate such interference. In order to avoid frequent cleaning of the optics and flow handling components, installation of a Teflon filter between the ambient sample line and the sample port of the analyzer must be done before the operation of the analyzer. A 5.0-micron Teflon filter will not degrade the ozone concentration. However, if particulate matter builds up on the filter, the particulate matter will destroy some of the ozone in the sample. The filter must be inspected on a bi-weekly basis and changed as needed.

Since the instrument's exhaust consists of ambient air with some ozone removed, ensure that the exhaust cannot re-enter the sample system.

Install the monitor's electrical connections as indicated in the operating manual.

The power backup, data acquisition equipment, and any monitoring equipment, calibration equipment, or other ancillary equipment should be installed according to information supplied in the appropriate operating manuals.

1.5.5 Programming Equipment

When the instrument is first turned on, the exhaust fan will start and the Power-Up and Self-Test screens will be displayed. These screens will be displayed until the instrument has completed its warm up and self-checks. Allow 30 minutes for the instrument to stabilize.

After the warm-up period the Run Screen, or Normal Operating Screen, is displayed. The Run Screen displays the ozone concentration. Press the MENU button to access the Main Menu, which contains a list of submenus. Instrument parameters and features are divided into the submenus according to their function. Use the ↑ or ↓ buttons to move the cursor to each submenu.

1.5.5.1 Range and Units

The Range Screen defines the concentration range of the analog outputs. Polk County Air Quality will use the “Single Range” option with the selected range of 0 – 0.250 ppm for the analyzer. To set the range for the instrument, press the MENU button to access the Main Menu. Press the ↓ button until the cursor is on **RANGE**, and press **ENTER** to display the O₃ Range Menu. Press the ↓ button until the cursor is on **SET CUSTOM RANGES**, and press **ENTER**. Press the ↓ button to scroll to **CUSTOM RANGE 1** and press **ENTER**. Use the ← and → buttons to move the cursor left or right. Use the ↑ or ↓ buttons to increment or decrement the numeric value to set the range to “0.250” and press **ENTER**. Press **MENU** to return to the Range Menu.

The Gas Units Screen defines how the ozone concentration reading is expressed. From the Range Menu, select **GAS UNITS** to display the Gas Units screen. Use the ↓ button to select “PPM” and press **ENTER**. Press **MENU** twice to return to the Run Screen.

1.5.5.2 Averaging Time

The averaging time defines a time period (1 to 300 seconds) during which ozone measurements are taken. The average concentration of the readings is calculated for that time period. Polk County Air Quality will use the setting of 60 seconds as the averaging time for the collection of data. An averaging time of 60 seconds will also be used during calibrations, audits, and zero/precision/span checks.

From the Main Menu, use the ↓ button to scroll to **AVERAGING TIME** and press **ENTER**. From the Averaging Time Screen, use the ↑ or ↓ buttons to scroll through the preset ranges. Press **ENTER** to select the desired averaging time. Press **RUN** to return to the Run Screen.

1.5.5.3 Temperature Compensation

Temperature Compensation provides compensation for any changes to the instrument’s output signal due to variations in sample gas temperature. When the temperature correction is off, the first line of the display shows the factory standard temperature of 0°C. Polk County Air Quality will run the ozone analyzer with the temperature correction set to **ON**.

From the Main Menu, use the ↓ button to scroll to **INSTRUMENT CONTROLS** and press **ENTER**. From the Instrument Controls Screen, use the ↓ button to scroll to **TEMPERATURE COMPENSATION**, and press **ENTER**. Press **ENTER** to toggle the temperature compensation on or off. Press **RUN** to return to the Run Screen.

1.5.5.4 Pressure Compensation

Pressure Compensation provides compensation for any changes to the instrument's output signal due to variation of sample pressure. When the pressure correction is off, the first line display shows the factory standard pressure of 760 mmHg. Polk County Air Quality will run the ozone analyzer with the pressure correction set to **ON**.

From the Main Menu, use the ↓ button to scroll to **INSTRUMENT CONTROLS** and press **ENTER**. From the Instrument Controls Screen, use the ↓ button to scroll to **PRESSURE COMPENSATION**, and press **ENTER**. Press **ENTER** to toggle the pressure compensation on or off. Press **RUN** to return to the Run Screen.

1.5.5.5 Baud Rate

The Baud Rate Screen is used to set the RS-232 interface baud rate. The Polk County Air Quality Department will use a baud rate of 9600.

From the Main Menu, use the ↓ button to scroll to **INSTRUMENT CONTROLS** and press **ENTER**. From the Instrument Controls Screen, use the ↓ button to scroll to **COMMUNICATION SETTINGS** and press **ENTER**. From the Communication Settings Screen, use the ↓ button to scroll to **BAUD RATE**, and press **ENTER**. Use the ↑ or ↓ buttons to scroll through the preset rates. Press **ENTER** to select the desired baud rate. Press **RUN** to return to the Run Screen.

1.5.5.6 Clock Set

To set the correct time and date on the instrument, press **MENU** to return to the Main Menu. Use the ↓ button to scroll to **INSTRUMENT CONTROLS** and press **ENTER**. Use the ↓ buttons to scroll to **DATE/TIME** and press **ENTER**. The date and time should be set to the Agilaire Model 8832 Data logger time. Use the → button to select: year, month, day, hour, minutes, or seconds. Use the ↑ or ↓ buttons to increase/decrease the desired value. Set the appropriate date and time and press **ENTER**. Press **RUN** to return to the Run Screen. The instrument is now set with the appropriate time, date, full scale range and units.

NOTE: The clock should be checked at each site visit and synced to the time on the data logger.

NOTE: It is recommended that you allow the 49i 24-hours before you attempt checks or calibration.

1.6 Standards

In ambient air monitoring applications, precise ozone concentrations called standards are required for the calibration of ozone analyzers. Ozone standards cannot be stored for any practical length of time due to the reactivity and instability of the gas. Therefore, ozone standards must be generated and certified on site. Environmental Protection Agency (EPA)-Region 7 maintains a highly accurate standard photometer known as a

Standard Reference Photometer (SRP) to serve in lieu of Standard Reference Materials (SRMs). The EPA-Region 7 SRPs provides National Institute of Standards and Technology (NIST) traceable ozone standards that are accessible to Polk County Air Quality for verifying the local primary standards. Polk County Air Quality maintains ozone standards which are classified into two basic groups: primary standards and transfer/audit standards.

Polk County Air Quality operates its own local primary standard photometer that serves as the single master standard for all ozone calibrations performed by Polk County Air Quality. The local primary standard photometer is operated as described in reference 1.3.3. The transfer and audit standards described in sections 1.6.2 and 1.6.3 are used as working standards to calibrate and audit the ozone monitoring analyzers. These transfer and audit standards are all referenced to the local primary standard.

1.6.1 Local Primary Standards

The local primary standard (PS) is used to check the accuracy of ozone transfer/audit standards and analyzers. An ultraviolet (UV) photometer is designated as the primary standard, recognized as the authority capable of generating and measuring ozone concentrations with impeccable accuracy. The concentrations generated by the designated primary ozone standard are recognized as the most accurate ozone concentrations available. It is required that the primary photometer used for the calibration of these standards be dedicated exclusively to such use, never used for ambient air sampling and maintained under meticulous conditions.

Primary standards are compared against EPA Region 7's Standard Reference Photometer (SRP) once a year, prior to the start of ozone season. EPA Region 7 requires that the local PS be transported to their laboratory for the annual calibration.

The Iowa Department of Natural Resources (IDNR) has developed certification spreadsheets and instructions for the EPA to use as part of their annual certification/recertification process, along with a checklist to accompany the primary standards to EPA Region 7. These materials were created in collaboration with, and were approved by, EPA Region 7. The "Ozone Primary Standard Certification Worksheet" (Forms 1-1 to 1-3, Appendix A) will be used to determine if the primary standards pass their annual certification. See Appendix B for detailed instructions for using the Ozone Primary Standard Certification Worksheet. A copy of the "Checklist for Certification of Iowa Ozone Primary Standards Against EPA's Standard Reference Photometer" can be found in Form 2, Appendix A.

Occasionally, it may become necessary for Polk County Air Quality to switch from their primary PS to a back-up PS. If both primary standards were certified at opposite ends of the EPA's acceptable limits, the portable transfer standards might lose their certification as a result of the transition between primary standards. Consequently, Polk County Air Quality has adopted the policy of correcting the readings of their primary standards to better match the SRP. The "Ozone Primary Standard Certification Worksheet" (Forms 1-1 to 1-3, Appendix A), and the "1x6 Averages Worksheet for Certification of Ozone Transfer Standards" (Form 3, Appendix A) facilitate the process of making these corrections.

While the "Ozone Primary Standard Certification Worksheet" will generate the appropriate slope and intercept needed to correct the PS, the "1x6 Averages Worksheet for Certification of Ozone Transfer Standards" will actually make the correction, Form 3, Appendix A. This worksheet adjusts the raw ten minute average of the PS, based on the slope and intercept entered into the cells in its extreme upper right corner "Slope (M) of PS Correction Equation" and "Intercept (I) of PS Correction Equation.

The equation embedded in the formulas of the “Corrected Averages” row in the 1x6 Averages Worksheet for Certification of Ozone Transfer Standards is:

$$\text{Corrected Primary Standard conc.} = 1/M (\text{Indicated Primary Standard conc.} - I).$$

See Appendix C for detailed instructions for using the 1x6 Averages Worksheet for Certification of Ozone Transfer Standards.

NOTE: the ten minute averages for the transfer standard are the same in both the “Average” and “Corrected Average” rows of the “1x6 Averages Worksheet”. Corrected 10 minute averages for the primary standard should be obtained from the “Corrected Averages” row of the “1x6 Averages Worksheet” and transferred to the “6x6 Transfer Standard Calibration Linear Regression Worksheet” in the column labeled “Primary Standard”.

Figure 1-1: Typical Calibration Setup of an Ozone Transfer/Audit Standard

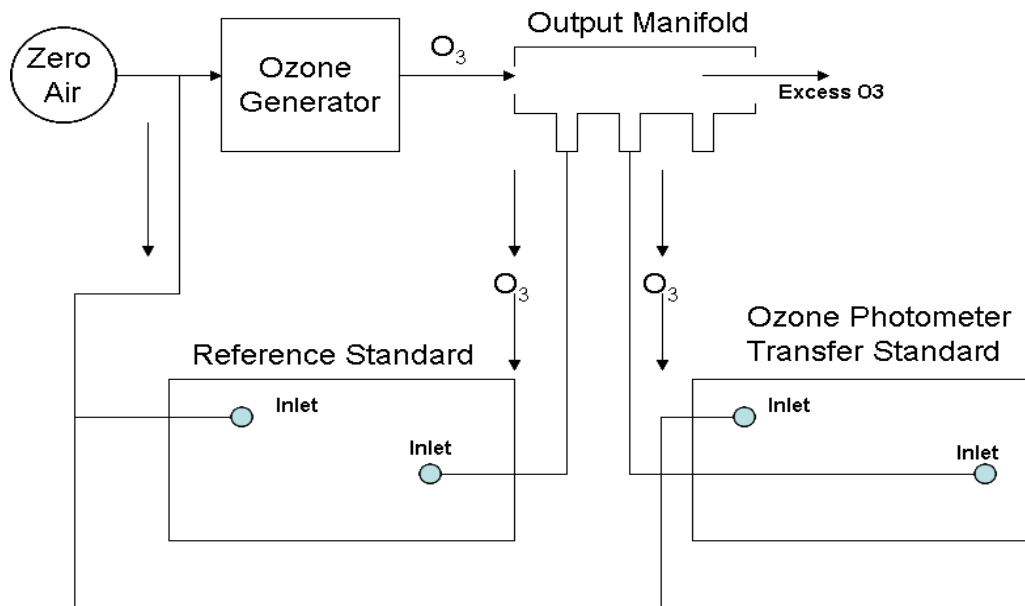

1.6.2 Transfer Standards

Transfer standards are used to calibrate the station field analyzer and to perform precision and calibration checks. Instruments designated as transfer standards are used so the primary standard can remain at a fixed laboratory location where conditions can be carefully controlled and damage to the instrument minimized. Transfer standards are calibrated against the higher-level, primary standards. By using transfer standards, all of the ozone analyzer calibrations in Polk County Air Quality’s air monitoring network are related to the UV photometer designated as the primary standard. All transfer standards must meet the qualification requirements described in reference 1.3.3. All transfer standards must be accompanied by the following:

- A zero air generator that gives an output of at least 10 psig. The generator is equipped with dual scrubbers of charcoal and a Purafil Scrubber to remove any water vapor or contaminants which may result in scrubbing. See Polk County Air Quality SOP Section 25 for instructions for the Teledyne 701 Zero Air Generator.

- The manufacturer's manuals for the instruments.
- Current certification relationship information (slope and intercept) applicable to current use of the transfer standard, together with any corrections or restrictions in the operating conditions.
- A complete listing and description of all equipment, materials, and supplies necessary or incidental to the use of the transfer standard.
- A complete and detailed operational procedure for using the transfer standard, including all operational steps, specifications and quality control checks.

1.6.3 Audit Standards

Audit standards are used to challenge the station field analyzer and to perform accuracy checks on a quarterly basis. Instruments designated as audit standards are used so the primary standard can remain at a fixed laboratory location where conditions can be carefully controlled and damage to the instrument minimized. Audit standards are calibrated against the higher-level, primary standards. By using audit standards, all of the ozone analyzer calibrations in Polk County Air Quality's air monitoring network are related to the UV photometer designated as the primary standard. All audit standards must be accompanied by the following:

- A zero air generator that gives an output of at least 10 psig. The generator is equipped with dual scrubbers of charcoal and a Purafil scrubber to remove any water vapor or contaminants which may result in scrubbing. See Polk County Air Quality SOP Section 25 for instructions for the Teledyne 701 Zero Air Generator.
- The manufacturer's manuals for the instruments.
- Current certification relationship information (slope and intercept) applicable to current use of the audit standard, together with any corrections or restrictions in the operating conditions.
- A complete listing and description of all equipment, materials, and supplies necessary or incidental to the use of the audit standard.
- A complete and detailed operational procedure for using the audit standard, including all operational steps, specifications and quality control checks.

1.7 Qualification, Certification and Recertification

Qualification consists of demonstrating that the transfer and audit standards are sufficiently stable (repeatable) to be useful as a transfer standard. Repeatability is necessary over a range of variables such as temperature, line voltage, barometric pressure, elapsed time, operator adjustments, or other conditions, any of which may be encountered during use of the transfer standard. These variables are performed by the manufacturer. After a transfer or audit standard has been shown to meet the qualification requirements, certification is required before it can be used.

Certification requires the averaging of six comparisons between the transfer standard and the local primary standard. Each comparison covers the full range of ozone concentrations. It is required that the primary standard generate six (6x6 calibration) ozone concentrations on a different day within a 14-day period. For each comparison, the slope (m) and intercept (I) is computed by a least squares linear regression, Form 4, Appendix A. During Certification and Recertification, the more authoritative standard (i.e. Primary Standard) readings are the X coordinates; and the less authoritative standard (Transfer Standards that go to the trailer) are the Y coordinates). A preliminary calibration relationship is determined using the following equations:

Equation 1

$$m(\text{slope}) = \frac{\sum xy - \frac{(\sum x)(\sum y)}{n}}{\sum x^2 - \frac{(\sum x)^2}{n}}$$

Equation 2

$$I(\text{y intercept}) = y - mx$$

When the comparisons are completed, the average slope from the six individual slopes is determined using equation 3:

Equation 3

$$\bar{m} = \frac{1}{6} \sum_{i=1}^6 m_i$$

The average intercept from the six individual intercepts is determined using the equation 4:

Equation 4

$$\bar{I} = \frac{1}{6} \sum_{i=1}^6 I_i$$

The relative standard deviation of the six slopes (s_m) is determined using the equation:

Equation 5

$$s_m = \frac{100}{\bar{m}} \sqrt{\frac{1}{5} \left[\sum_{i=1}^6 (m_i)^2 - \frac{1}{6} (\sum_{i=1}^6 m_i)^2 \right]}$$

The standard deviation measures the variation in the data set by determining how far the data values are from the mean, on the average.

The value of s_m in equation 5 must be $\leq 3.7\%$ to maintain certification.

The quantity (s_I) for the six intercepts is determined using the equation 6:

Equation 6

$$s_I = \sqrt{\frac{1}{5} \left[\sum_{i=1}^6 (I_i)^2 - \frac{1}{6} (\sum_{i=1}^6 I_i)^2 \right]}$$

The value of S_I in equation 6 must be ≤ 1.5 ppb to maintain certification.

The calibration relationship is computed as:

Equation 7

$$\text{Qualified Transfer Standard conc.} = \frac{1}{\bar{m}} (\text{Indicated Transfer Standard conc.} - \bar{I}).$$

A thorough explanation of ozone analyzers, procedures, and requirements, is contained in EPA-454/B-13-004-Technical Assistance Document, October, 2013. Transfer Standards for the Calibration of Ambient Air Monitoring Analyzers for Ozone.

Documentation of calibration and certification to the local primary standard must always remain with the transfer or audit standard for ready access if data collection procedures are questioned during audits. Recertification involves annual and quarterly six point comparisons between the primary standard and the transfer standard. EPA recommends that a transfer standard, which remains at a fixed monitoring site, be recertified once per quarter if it is sufficiently stable to avoid loss of certification over that time period. To demonstrate the stability of the instrument, the operator must perform and document routine checks during each station inspection.

To recertify a transfer standard during ozone season after an initial 6x6 comparison against the primary standard, the following steps will be taken:

- A new 1x6 comparison is made between the transfer standard and the primary standard
- Determine if the slope of the newest 1x6 is within $\pm 5\%$ of the average slope for the 6x6
- If the slope of the newest 1x6 is within $\pm 5\%$ of the average slope for the 6x6, the oldest 1x6 is tentatively replaced with the most recent 1x6
- Compute a new average slope, new average y intercept, a new S_m and a new S_i . If the acceptance criteria specified above for S_m and S_i are met, the replacement of the oldest 1x6 with the 1x6 just completed can be considered final
- Substitute the new average slope and new average y intercept in equation 7, to compute a new correction equation

Should the transfer standard fail to meet the acceptance criteria during the latest 1x6 comparison, it loses its certification and the problem must be investigated and corrected. Under these circumstances, all the initial certification steps (six comparisons on different days within a 14 day period) must be repeated. Although the calibration factors (O3 BKG and O3 COEF) on the transfer standard can be adjusted prior to the first run of a 6x6 comparison, any subsequent adjustments require that all 6 runs of the 6x6 comparison be redone. All 6 runs of the 6x6 comparison are also performed at the start of each ozone season.

1.8 Calibrations

The Thermo Scientific Model 49i Ozone monitor is calibrated whenever the following occurs: Annually, following instrument repair, and when an automated nightly or manual bi-weekly zero/precision/span check fails to meet acceptance criteria limits. The local primary standard, transfer standard and audit standard calibrations are outlined in detail in Sections 1.7 and 1.8. The site analyzers are typically calibrated in the field against the transfer standard with generated ozone concentrations of approximately: 0.200 ppm, 0.150 ppm, 0.100 ppm, 0.050 ppm, and zero air.

On the main screen of the 49i Transfer Standard (TS), Press the **RUN** button until the zero display lights up in the lower left corner on the display screen. The TS is now in zero air sampling mode. With the zero air flowing, verify that the transfer standard and data logger reads 0.000 ppm \pm 0.005 ppm. Allow the analyzer to sample zero air until a stable reading is obtained on the O₃ channel.

Press the front panel **MENU** button on the 49i site analyzer to display the Main Menu. Use the arrow keys to select **CALIBRATION** and press **ENTER** to display the Calibration Menu. Select **CALIBRATE ZERO** and press **ENTER**. In the Calibrate Zero Screen, press **ENTER** to set the O₃ reading to zero. Press the **MENU** button to return to the Calibration Menu.

On the TS, turn the ozonator on. Push the **MENU** button, scroll to **INSTRUMENT CONTROLS** and press **ENTER**. Scroll to **OZONATOR SOLENOID** and press **ENTER** twice to turn the ozonator on.

On the main screen of the Transfer Standard, Press the **RUN** button on the TS until the **LEVEL 1** display lights up in the lower left corner on the display screen. Press the **MENU** button, scroll to **INSTRUMENT CONTROLS** and press **ENTER**. Scroll to **CUSTOM O3 LEVELS** and press **ENTER**. Scroll to **LEVEL 1** and press **ENTER**. Adjust the O₃ concentration to approximately 90% the upper range limit (URL) of 0.250 ppm (i.e. 0.225 ppm). Allow the TS and data logger to obtain stable readings on the O₃ channel.

Press the front panel **MENU** button on the 49i site analyzer to display the Main Menu. Use the arrow keys to select **CALIBRATION** and press **ENTER**. Scroll to **CAL O3 COEF** and press **ENTER**. Use the ← and → buttons to move the cursor left and right. Use the ↓ or ↑ buttons to increment and decrement the digit to the expected O₃ concentration and press **ENTER**.

After the zero and 90% URL points have been set, determine at least 3 approximately evenly spaced points between zero and the 90% URL without further adjustment to the analyzer. Perform the calibration check by a direct comparison between the 49i TS and data logger. Allow the TS and data logger to obtain stable readings on the O₃ channel. Once the readings have stabilized, wait a minimum of 5 minutes then record the 1-minute average as displayed on the data logger. Record all information on the Calibration Field Sheet, Form 5, Appendix A.

Generate the regression analysis calculations by least squares the slope, intercept, and correlation coefficient of the site analyzer response versus the calibration standard concentrations, Form 6, Appendix A. Acceptance criteria can be found in Table 1-1: The Measurement Quality Acceptance Tables from the Quality Assurance Handbook for Air Pollution Measurement Systems, Volume II, Appendix D. Revision 1, March, 2017.

A thorough explanation of ozone analyzers, procedures, and requirements, is contained “EPA-600/4-79-057 September 1979, Technical Assistance Document for the Calibration of Ambient Ozone Monitors”.

1.9 Quality Control

1.9.1 Station Inspection

Before entering the station, the perimeter should be inspected for damage. Extreme weather conditions, neglect of station maintenance or vandalism that may have resulted in damage to the site since the operator's last visit. Check that the sample probe is intact and has not been damaged.

1.9.2 Station Log Book

A station log book must be maintained at each monitoring site and should accurately reflect site operations. The log book will be identified with the station name, station number, date, time, operator, instrument identification, parameter, scale and units. All entries shall include the date, time, quality control checks, and maintenance on equipment, audits, equipment changes and missing or invalid data. Additional information should include: maintenance performed on the station, abnormal traffic patterns, nearby construction, or sample line cleaning.

Should the data be challenged, the information recorded in the log book is invaluable. A written record of observations concerning abnormal operations or localized occurrences is critical if a violation of ambient air standards were recorded during this period. Completed log books be maintained by Polk County Air Quality and will be archived for future reference.

Once the operator has entered the monitoring station, she/he should first:

- Check for any obvious analyzer malfunctions. For example, check to see that the equipment is running, the pumps are operating and the instrument is cycling properly.
- Note any unusual odors or noise. An unusual odor may indicate a point source of a pollutant or a strange new noise can indicate a malfunction in the equipment. These observations should be recorded in the station log book and may prove to be invaluable if the data is challenged.

Once the initial inspection is made, the operator must proceed with a routine inspection and perform a zero/precision/span check on the ozone analyzer.

The station operator is responsible for making several observations during the station inspection. Any of the above described observation must be thoroughly detailed in the site log book.

1.9.3 Bi-Weekly Zero, Precision and Span Checks

The zero/precision/span check is a quality control procedure used to verify that the air monitoring system is operating properly. The check involves comparing the response of the station analyzer to ozone concentrations generated by the station transfer standard. The deviation between the "indicated" value of the analyzer and the "actual" or "true" value of the transfer standard is then determined.

Zero air and target ozone concentrations of 70 ppb (the precision) and 200 ppb (the span) are generated by the transfer standard. Each concentration is measured by the transfer standard and the station analyzer. The results are recorded on the Ozone Field Sheet, Form 7, Appendix A.

Following the zero, precision and span check, the deviation from the true ozone value is determined using **Equation 7**.

The following critical criteria require recalibration of the field analyzer and invalidation of the data unless there is compelling reason and justification not to do so:

- The zero drift is outside of ± 5.1 ppb
- The precision difference is ± 1.5 ppb, or $\pm 7.1\%$, whichever is greater.
- The span drift is outside $\pm 7.1\%$

Acceptance criteria can be found in Table 1-1: The Measurement Quality Acceptance Tables from the Quality Assurance Handbook for Air Pollution Measurement Systems, Volume II, Appendix D. Revision 1, March, 2017.

For assessing bi-weekly zero and span drift, the current measured instrument response will be compared to the current known value. Corrective action will be taken if the difference is outside of historically established control limits.

The zero/precision/span check must be performed at a minimum of once every fourteen days and is always performed in the same manner. Failure to perform and document zero/precision/span data within the required frequency and concentration may result in the invalidation of data. The operator is required to submit the completed field sheet form to the Quality Assurance Officer for review. Refer to Section 1.14.4 for more detailed procedures on Zero, Precision and Span Checks.

1.9.4 Agreement Between Collocated Monitors:

In the event that hourly readings from the collocated monitors at a site repeatedly differ by more than 3.0 ppb, Polk County will initiate an investigation to determine the cause of differences. Even though some variation between two different monitors is to be expected, if it is found that the cause is outside of normal operation, corrective actions will be taken to restore agreement between the two monitors.

1.9.5 Data Quality Objectives

Data collected for the ambient air quality-monitoring program are used to make very specific decisions that can have an economic impact on the area represented by the data. Data Quality Objectives (DQO's) are a full set of performance constraints needed to design an environmental data collection activity (EDCA). This includes a specification of the level of uncertainty that a data user is willing to accept in the data to which the decision will apply. The DQO will be based on the data requirements of the decision-maker.

Decision-makers need to feel confident that the data used to make environmental decisions are of adequate quality. Data used in these decisions are never error free and always contain some level of uncertainty. Because of these uncertainties some false positive or false negative error may occur. Decision-makers need to understand and set limits on the probability of making incorrect decisions with these data. One needs to understand and control uncertainty. Uncertainty is the sum of all sources of error associated with an EDCA.

Some of these measurement uncertainties include error associated with field, preparation and laboratory activities. The goal of the QA program is to control measurement uncertainty to an acceptable level through various quality control techniques.

Three data quality indicators used in determining total measurement uncertainty, they are:

- **Precision-** a measure of mutual agreement among individual measurements of the same property usually under prescribed similar conditions. This is the random component of error.
- **Bias-** the persistent distortion of a measurement process which causes an error in one direction. Bias determines the positive or negative deviation from the true value.
- **Detectability-** the determination of the low range value that a method specific procedure can reliably detect. The method detection limit (MDL) or detectability refers to the

lowest concentration of a substance that can be determined by a given procedure. The 49i must be able to detect a minimum value of 1.0 ppb of O₃. The site specific MDL's should be determined for each instrument. Use 40 CFR Part 136 App B as the guideline for determining the MDL of the instrument.

1.9.6 Data Acquisition and Telemetry

Data acquisition involves retrieval of the ambient air quality data from the data logger. The station operator has the primary responsibility for distinguishing valid measurements from indications caused by malfunctioning instruments or source interferences. The telemetry system can be used by a station operator to scan data transmitted from the monitoring station to a central location. This enables the operator to "call" the monitor site and examine the data recorded at the monitoring station (e.g. ozone concentrations and station temperature). The station operator should be familiar with daily concentration variations (i.e. the times daily maximum concentrations occur and the interrelationship of NO_x). By recognizing abnormal data, the operator is alerted that the instruments may not be operating properly and a station visit may be necessary. However, monitoring a station by telemetry is not to be substituted for the site visit. See Polk County Air Quality SOP Section 18 for instructions on data acquisition.

In the event of an exceedance of the 8-hour Ozone standard, data averages of no longer than 5 minutes will be critical for validating the data and investigating the cause of the exceedance. All data loggers are set up to collect 1 minute, 5 minute and 1 hour averages, with 1 minute being the "base average". The 5 minute and hourly averages are called "extended average #1 and #2, respectively. The 1 minute, 5 minute and 1 hour averages are polled and stored before the data is overwritten. For more specific instructions on data acquisition, see Polk County Air Quality AirVision SOP Section 18.

1.10 Equipment, Maintenance and Trouble Isolation

1.10.1 Preventative Maintenance

Each instrument must be periodically examined and serviced to anticipate and prevent instrument failure. Scheduled maintenance on the instruments will prevent costly repairs and loss of data. The routine maintenance required on the analyzers by the station operator is minimal and outlined in the manufacturer's manual. By keeping track of the instrument responses from week to week, the operator can observe trends, which would alert the operator of a potential problem, and to correct the situation before the instrument fails. A preventative maintenance schedule is provided for the operator at the end of these procedures.

1.10.1.1 Replace Ozone Scrubber

The ozone scrubber should be replaced every three years. If a problem with the ozone scrubber is suspected, a scrubber efficiency test described in the operator's manual should be performed. If the scrubber efficiency test fails then the scrubber must be replaced.

1.10.1.2 Sample Frequency Adjustment

The sample frequency will decrease as dirt and dust particles collect throughout the optical path, as the UV lamp output decays, or as the efficiency of the detector diminish. If the adjusting procedures fail to restore the frequency to adequate levels, cleaning of the optics or replacement of the UV lamp may be necessary (this procedure is detailed in the manufacturer's manual). The manufacturer's manual contains several good diagrams which will help the operator locate the source block.

1.10.1.3 Automatic Temperature and Pressure Compensation

The automatic temperature and pressure compensation features of the Thermo 49i must be enabled. The temperature and pressure sensors will be verified yearly prior to annual calibration.

1.10.1.4 Analyzer Leak Check

An analyzer leak check should be performed on a yearly basis, or as needed for trouble shooting purposes. To perform an analyzer leak check, disconnect the sample line from the **SAMPLE INLET** on the back panel, and plug the fitting.

Press the **MENU** button to display the Main Menu. Use the ↓ buttons to scroll to **DIAGNOSTICS** and press **ENTER**. From the Diagnostic Menu, use the ↓ buttons to scroll to **SAMPLE FLOW** and press **ENTER**. The flow reading should slowly drop to zero. Press the **MENU** button to return to the Diagnostics Menu. Use the ↓ buttons to scroll to **PRESSURE** and press **ENTER**. The pressure reading should drop below 250 mmHg. If the flow and pressure do not drop to their desired limits, there is a leak in the system. Check to see that all fittings are tight, and none of the input lines are cracked or broken.

1.10.1.5 Sample Line Leak Check

A sample line leak check should be performed on a yearly basis, and anytime a new sample line is installed. Unscrew the sample line from the back of the analyzer, and connect the vacuum pressure gauge. The sample line must be capped off on the top side of the roof before proceeding.

Turn vacuum pump on and wait for the pump to remove all air from the sample line. The vacuum gauge will indicate a steady reading of approximately 21 inches of Hg vacuum when the lines have been evacuated. The vacuum reading must be at least 15 inches of Hg for the leak check to take place.

Close the valve that is located between the vacuum gauge and the pump. Once the valve is closed record the reading from the gauge and start a timer. Shut the pump off and wait 1-minute. Record the reading from the vacuum gauge.

The acceptable leak rate for the sample lines is 0.5 inches of Hg for the 1-minute check. If the leak check fails, make sure all lines are connected securely to the vacuum gauge and the line is capped off the roof, and repeat the check. If a second leak check fails, look for the leak and/or replace sample line if needed.

1.10.1.6 Pressure Check (psi) Flow Rate

Before each zero/precision/span check, audit or calibration the internal pressure of the transfer or audit standard must be set to 10 psi. This will ensure that the zero air and ozone concentrations are delivered at excess to the analyzer.

1.10.1.7 Solenoid Leak Check

To perform a solenoid valve leak check, remove the sample line from the **SAMPLE INLET** on the back panel. Remove the ozone scrubber, and locate the Kynar elbow on the solenoid valve. This is the **ZERO AIR INLET**.

Plug the **ZERO AIR INLET** (a finger may be used). The flow, as indicated on the flow meter, should drop to zero. If it does not, there is a leak in the system. If no leaks were found, reconnect all in-cabinet plumbing and perform a system leak check.

1.10.1.8 Particulate Filter Changes

A 5.0 micron Teflon filter housed in a Teflon filter holder is located on the outside of the analyzer and is connected to the sample line. The filter should be checked once every two weeks, and changed when noticeably dirty. Slow response of the analyzer during the zero/precision/span check is an indication of a dirty filter or contaminants in the sample line. To replace the used filter, loosen the two halves of the filter holder and replace the dirty filter with a new filter.

Following a filter change, perform a high span check (approximately 200 ppb) for at least half an hour. This is to condition the new filter and serves as a check to see if there any leaks in the reassembled filter holder.

1.10.1.9 Replacing Sample Lines

It is the operator's responsibility to maintain the sample lines. The sample lines must be replaced if the operator suspects a loss in Ozone concentrations due to contamination in the line, or every year.

1.10.2 Trouble Isolation

The instruments in Polk County Air Quality's air monitoring network are very reliable. However, after a period of continuous use problems may occur. Leaks in the system, dirt build up and UV lamp failure are typical. After time, the operator should be able to quickly distinguish the symptoms and causes of equipment failure.

It is suggested that each station operator consult the Models 49i, UV Photometric Ozone Analyzer, Instruction Manuals and compile personal notes on troubleshooting as they gain experience with the Thermo Scientific. The operator is encouraged to contact the manufacturer when attempting any repairs.

The manufacturer's manual is the best resource the station operator has for the information on the operation and maintenance of the ozone analyzer.

1.10.3 Environmental Control for Monitoring Equipment

Instrument vibration should be reduced as much as possible. Use shock-absorbing feet for the monitor. Any pumps must be fitted with rubber feet to reduce vibration. All pumps connected to the analyzer should be connected using tubing that will prevent the transfer of vibrations back to the instrument and/or the instrument rack.

All instruments should be shielded from natural or artificial light.

Ensure constant voltage to surge protection devices and equipment.

Regulate the housing temperature between 20-30°C. Hourly temperature readings are collected by the polling computer during daily polling. Polk County will make every effort to operate the monitor in the 20-30°C range. Data will be investigated to determine the validity of the data for hourly concentrations where the shelter temperatures fall outside the range of (20-30°C).

1.11 Quality Assurance (Accuracy - Audits)

Once during each calendar quarter, the designated Quality Assurance Officer utilizing the procedures and calculations specified in 40 CFR 58, Appendix A, "Quality Assurance Requirements for State and Local Air Monitoring Stations (SLAMS)," each of the operating ozone analyzers will be audited using a direct comparison.

1.11.1 Direct Comparison Audits

During a direct comparison audit, an audit standard and the monitoring station's ozone analyzer assay the same ozone concentrations at the same time. An audit standard that has meet the qualification and certification requirements in Section 1.7 – Qualification, Certification, and Re-certification, is required before it can be used. The responses of the on-site analyzer are then compared against the output of the audit standard and a linear regression is generated.

1.11.2 Audit Sequence

Connect the audit standard and the site monitor as shown in Figure 1-2. Allow the site monitor and audit standard to sample the zero air until the site monitors response does not vary by more than $\pm 2\%$ of the measurement range over a 5-minute period. For Polk County Air Quality monitors the upper range limit is set to 250 ppb. The zero air reading should not vary by more than 5 ppb over a 5-minute period. Record the zero air readings on the Audit Field Sheet, Form 8, Appendix A.

Generate at least three of the following CFR audit concentrations: 0.004-0.0059 ppm, 0.006-0.019 ppm, 0.020-0.039 ppm, 0.040-0.069 ppm, 0.070-0.089 ppm, 0.090-0.119 ppm, 0.120-0.139 ppm, 0.140-0.169 ppm, 0.170-0.189 ppm, and 0.190-0.259 ppm. One point must be within two to three times the method detection limit of the instruments. The second point will be less than or equal to the 99th percentile of the data at the site or the network of sites in the PQAQ or the next highest audit concentration level. The third point can be around the primary NAAQS concentration or the highest 3-year concentration at the site or the network of sites in the PQAQ.

Both the audit standard and site analyzer readings should be taken only after a stable response is exhibited by both instruments. Once the readings have stabilized, wait a minimum of 5 minutes then record the most recent 1-minute rolling average as displayed on the data logger for the site analyzer and the audit standard. Calculate the audit concentrations using equation 7, Section 1.8. **Note:** adjust the audit response based on the audit analyzer 6x6 linear regression.

Generate the highest audit concentration level first. Then consecutively generate the decreasing concentrations. After challenging the site analyzer with all audit concentrations, record all data on the audit form. Calculate the percent difference for all audit levels using the following equation:

Equation 8:

$$\% \text{ Difference} = \frac{C_M - C_A}{C_A} \times 100$$

Where:

C_M = ESC data logger concentration, ppm

C_A = Calculated audit standard concentration from equation 7, ppm

Generate the regression analysis calculations by least squares the slope, intercept, and correlation coefficient of the site analyzer response versus the audit standards concentrations.

The audit fails if any of the following acceptance criteria are not met:

- For EPA Audit Levels 1 and 2, the acceptance criteria is ± 1.5 ppb, or $\pm 15.1\%$, whichever greater
- The percent difference is outside $\pm 15.1\%$ for EPA Audit Levels 3-10.

If there is no reason to believe the results are incorrect or not representative of the analyzers performance, the cause for the audit failure must be investigated and corrected. An investigation initiated by audit results that are outside the above limits may require the invalidation of data. Record all information in the site log.

NOTE: For more detailed information concerning audit performances for O₃ monitoring, refer to the “Quality Assurance Handbook for Air Pollution Measurement Systems, Volume II” or 40 CFR 58.

Figure 1-2: Typical Setup of a Direct Comparison Audit

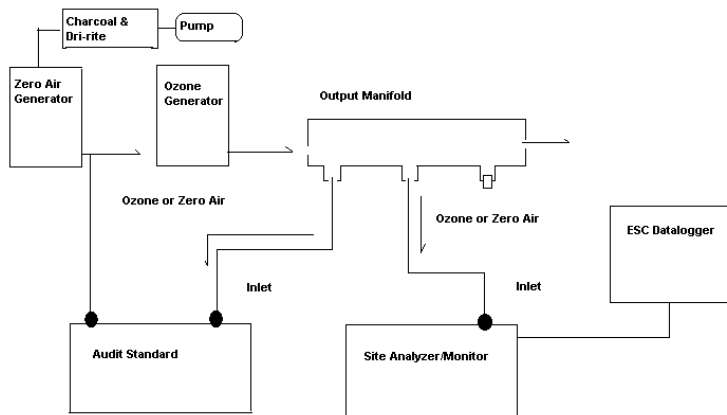

1.11.3 Federal Audits

Agency staff may be sent an audit device, such as for the National Performance Audit Program (NPAP). The agency staff does not know the ozone concentrations produced by the audit equipment. Responses of the on-site analyzer are then compared against those of the generator and a linear regression is calculated.

The Polk County Air Quality Department will participate in the USEPA performance audit program for ozone and in all other EPA audit programs, which may arise in the future. According to the March 2017 Redbook MQO Tables, The audit fails if any of the following acceptance criteria are not met:

- For EPA Audit Levels 1 and 2, the acceptance criteria is ± 1.5 ppb
- The percent difference is outside $\pm 10.1\%$ for EPA Audit Levels 3-10

If there is no reason to believe the results are incorrect or not representative of the analyzers performance, the cause for the audit failure must be investigated and corrected. An investigation initiated by audit results that are outside the above limits may require the invalidation of data. Record all information in the site log.

1.12 Data Quality Assessment

For each calendar quarter and year, Polk County Air Quality will prepare data precision, accuracy and completeness reports for the Iowa Department of Natural Resources (Iowa DNR) and EPA-Region 7 in accordance with the current Letter of Agreement (LOA).

1.12.1 Precision

The precision will be evaluated and reported employing the frequencies, procedures and calculations in 40 CFR Part 58, Appendix A, "Quality Assurance Requirements for State and Local Air Monitoring Stations (SLAMS)".

1.12.2 Accuracy

Using results from the performance audits and the calculations specified in 40 CFR 58, Appendix A, "Quality Assurance Requirements for State and Local Air Monitoring Stations". The accuracy will be evaluated and reported.

1.12.3 Data Completeness

The completeness of the data will be determined for each monitoring instrument and expressed as a percentage. Percent valid data will be a gauge of the amount of valid data obtained from the monitoring instrument, compared to the amount expected under ideal conditions (24 hours per day, 245 days per ozone season). Exceptions will be made for analyzers which have a seasonal sampling period, which were not installed at the beginning, or which were discontinued prior to the end of any reporting period for calculation purposes.

1.13 Procedures for Bi-Weekly Checks

New station operators will be provided with on-site training by an experienced operator before they operate a station on their own. The following procedures are intended to assist the operator in performing and documenting monitoring procedures. Monitoring personnel must become familiar with the Instruction Manual for Model 49*i* UV Photometric Ozone Analyzer, Figure 1-3.

A zero/precision/span check is required once every fourteen days. These checks must not be performed during periods of data collection which approach National Ambient Air Quality Standards (NAAQS) but postponed and performed after the air pollution episode. If the ambient ozone concentrations are exceeding or approaching 60 ppb, the check must be postponed.

No instrument adjustments are to be made prior to the zero/precision/span check. The purpose of the check is to verify that the air monitoring system is operating properly.

When approaching the monitoring station, make a brief survey of the structure housing the equipment and the condition of the sample probe intake. Look for any damage that may have occurred since the last visit.

Prevent the outside of the shelter from becoming overgrown and unkept by performing routine maintenance in and around the station.

Once in the station, perform a routine inspection. Note any unusual observations on the field data sheet.

Figure 1-3: Thermo Scientific 49i Analyzer



1.13.1 Maintenance Mode for Agilaire Data Loggers

During any maintenance, zero/precision/span checks, calibrations, audit or site visit the data logger must be placed into maintenance mode. This mode flags hourly data with an (M), indicating the analyzer is in the process of being checked by the site operator. Scroll to **LOGIN/SET USER LEVEL** and press **ENTER**. Login to the data logger using the appropriate password and press **ENTER**. Use the arrow keys to select Configuration Menu and press **ENTER**. Use the arrow keys to select **CONFIGURE (DATA) CHANNEL** and press **ENTER**. Use the arrow keys to select **PUT CHANNEL IN MAINTENANCE MODE** and press **ENTER**. Select the correct pollutant channel and press **ENTER**. Proceed with maintenance, weekly precision/span check, audit or calibration of the analyzer.

1.13.2 Remote Mode

Press the escape button (Esc) until the main menu is reached. Take the data logger out of maintenance mode when the task has been completed. Use the arrow keys to select Configuration Menu and press **ENTER**. Use the arrow keys to select **CONFIGURE DATA CHANNELS** and press **ENTER**. Use the arrow keys to select **TAKE CHANNEL OUT OF MAINTENANCE** and press **ENTER**. Press the escape button until the main menu is reached. Use the arrow keys to select **LOG OUT** and press **ENTER**.

1.13.3 Maintenance and Diagnostics Check

Check and record monitor readings on the data logger. Check and record any alarms on the analyzer. If alarms are present, check field sheet for out-of-control limits and perform any necessary maintenance. See Model 49i Instruction Manuals, Chapter 7-Servicing, and Section 1.1.15 Preventative Maintenance in this SOP. Then record any maintenance performed in the ozone maintenance log.

Check and record monitor's calibration factors. Press **MENU** and scroll down to **CALIBRATION FACTORS** and press **ENTER**. Record the O3 BKG and O3 COEF.

Write down any maintenance that was performed on the instrument or additional comments that may affect the air monitoring system. Examples include:

- replacement of UV lamps, pumps or tubing
- repairs or maintenance made to or around the shelter
- abnormal localized occurrences nearby
- suggestions for improvements to the system
- supplies that are needed
- checks or audits that were performed

1.13.4 Zero, Precision and Span Checks

The internal ozonator on the TS must be on for zero, precision and span checks. Since this system is setup for nightly auto-checks to occur, the TS ozonator should always be on. To verify that the TS ozonator is on, push the **MENU** button on the TS, scroll to **INSTRUMENT CONTROLS** and press **ENTER**. Scroll to **OZONATOR SOLENOID** and press **ENTER**.

The TS has been plumbed to the primary and collocated ozone analyzers in such a way that is conducive for nightly auto-checks to occur. Teflon tubing connects from the TS Ozone Port to a tee-connector that splits off between the primary and collocated ozone analyzers. For both the primary and collocated analyzers, there is another tee-connector between the ambient sample line and the line coming from the TS. This connection occurs prior to the particulate filter such that both sampled ambient air and ozone generated by the TS for bi-weekly manual checks both run through the Teflon particulate filter. Manually turn on the industrial timer by pressing the ON/OFF button to allow zero air to flow for the zero, precision and span check.

1.13.4.1 Span Check

The internal ozone level produced is a function of light intensity at 185 nanometers (nm) and gas flow. The light intensity is varied by changing the current, expressed as a percentage, into the lamp. The gas flow is held constant by a pressure regulator followed by a capillary.

Push the **RUN** button on the TS until the display reads Level 2. Level 2 has been programmed to provide a target ozone span concentration of 200 ppb. If a stable reading for level 2 is between 190-210 ppb, perform the span check. If the readings fall outside the range 190-210 ppb, adjust the Level 2 Output percentage so that the TS reads between 190-210 ppb. Press the **MENU** button, scroll to **INSTRUMENT CONTROLS** and press **ENTER**. Select **CUSTOM LEVELS** and press **ENTER**. Select **LEVEL 2** and press **ENTER**.

Polk County Air Quality uses the Agilaire Model 8832 data loggers for data recording. The values indicated on the data logger are the values that are being transmitted to, and recorded by the central computer. Therefore, it is important that the data logger readings are recorded on the field sheet.

Perform the span check by a direct comparison between the TS and the data logger. Allow the TS and site analyzers to stabilize, then wait a minimum of 5 minutes and take the most recent 1-minute rolling average concentrations for the TS and the data logger. Record data values in the Field Sheet Form 7, Appendix A.

Acceptance criteria can be found in Table 1-1: The Measurement Quality Acceptance Tables from the Quality Assurance Handbook for Air Pollution Measurement Systems, Volume II, Appendix D. Revision 1, January 2017.

1.13.4.2 Precision Check

At this point the span level readings have been recorded, perform the precision level check. Push the **RUN** button on the TS until the display reads Level 1. Level 1 has been programmed to provide a target ozone precision concentration between 0.070 ppm. If a stable reading for level 1 is between 60-80 ppb, perform the precision check. If the readings fall outside the range 60-80 ppb, adjust the Level 1 Output percentage so that the TS reads between 60-80 ppb. Press the **MENU** button, scroll to **INSTRUMENT CONTROLS** and press **ENTER**. Select **CUSTOM LEVELS** and press **ENTER**. Select **LEVEL 1** and press **ENTER**.

Perform the precision check by a direct comparison between the TS and the data logger. Allow the TS and site analyzers to stabilize, then wait a minimum of 5 minutes and take the most recent 1-minute rolling average concentrations for the TS and the data logger. Record data values in the Field Sheet Form 7, Appendix A.

Use **Equation 8** to determine the percent difference between the analyzer and the transfer standard. See Section 1.9.3 for acceptance criteria and corrective actions relating to zero, precision, and span checks. Record all information in the site log.

1.13.4.3 Zero Air Check

At this point the span and precision readings have been recorded, perform the zero air check.

Press the **RUN** button on the TS until the zero display lights up in the lower left corner on the display screen. The TS is now in zero air sampling mode. With the zero air flowing, verify that the transfer standard and data logger reads $0.0 \text{ ppb} \pm 5.1 \text{ ppb}$. Allow the TS and site analyzers to stabilize, then wait a minimum of 5 minutes and take the most recent 1-minute rolling average concentrations for the TS and the data logger. Record data values in the Field Sheet Form 7, Appendix A.

See Section 1.9.3 for acceptance criteria and corrective actions relating to zero, precision, and span checks.

Press the ON/OFF button on the industrial timer to turn off and discontinue zero air flow.

Log all site visits into the logbook (every detail of the visit must be logged).

Take the data logger out of maintenance mode. See Section 1.13.2.

NOTE: If a problem is recognized while performing maintenance, diagnostic, bi-weekly zero, precision or span checks which has or could affect data, a corrective action form is to be filled out describing the problem identified and the action taken to correct the problem, Form 9, Appendix A. All forms and documentation must be submitted to the Quality Assurance Officer.

1.13.4.4 Invalidate Data and Recalibrate

If the precision check results in a percent difference $\pm 7.1\%$, or if the zero drift is ≥ 5.1 ppb, or if the span drift is $\pm 7.1\%$, the site analyzer must be recalibrated and the data will be invalidated back to the last valid zero/precision/span check unless there is compelling reason and justification not to do so. See Section 1.8 for calibration procedures.

NOTE: In order to minimize data loss, Polk County personal will recalibrate the instrument when the results of bi-weekly checks reach or exceed recalibration thresholds, unless there is compelling reason and justification not to do so. Recalibration criteria refer to thresholds that typically require recalibrating the analyzer, but do not require the invalidation of data. Recalibration criteria should be set to levels that are as tight as practically possible, and based on historical performance data. They may change after reviewing typical differences from control charts.

1.14 Automated Zero/Precision/Span Checks

An external 24-hour Level 1 Zero/Precision/Span Check is performed using the auto function of the Thermo Scientific 49i. The auto checks are initiated by the 49i transfer standard to challenge the 49i site analyzer. The data is flagged for this period with a “C” on the data logger.

The automated zero, precision and span checks are used to determine if the 49i is operating properly, and if drift in instrument response has occurred. For these checks, the challenge gas should be sampled through as much of the sampling inlet system as practical to mimic the actual sampling of ambient air. The results of the Level 1 zero/precision/span checks should be plotted to graphically illustrate the trends in the response of the analyzer to the challenge gases.

Polk County Air Quality Division will analyze “drift” as a direct comparison of the current indicated concentration collected from the site analyzer to the actual concentration collected from the Transfer Standard. Polk County Air Quality Division will strive to obtain a zero drift ≤ 3.1 ppb, a span drift $\pm 7.1\%$ of the span level, and a difference for precision of 1.5 ppb or $\pm 7.1\%$, whichever is greater. If the daily automated Zero, precision or span check results are outside of these criteria, the instrument will be recalibrated and the data will be invalidated to the last acceptable check, unless there is a compelling reason and justification not to do so.

Site visits should be conducted if the daily results exceed the following limits. (All differences refer to the current analyzer reading compared to the current qualified known reading from the transfer standard):

- A Zero difference of 3.1 ppb
- A Span difference of greater than 5%
- A Precision difference of greater than 5%

There are several components to a successful automated zero/precision/span check:

- A zero air generator that gives an output of at least 10 psig. The generator is equipped with dual scrubbers of charcoal and a Purafil scrubber to remove any water vapor or contaminants which may result in scrubbing. See Polk County Air Quality SOP Section 25 for instructions for the Teledyne 701 Zero Air Generator.
- A solenoid system with timer

- A Calibration Program setup in the 49i Transfer Standard
- Digital Communication settings must be established in the AirVision Software for the Agilaire Model 8832 data logger
- A Calibration Program setup in the AirVision Software for the Agilaire Model 8832 data logger

1.14.1 Plumbing the system

The TS has been plumbed to the primary and collocated ozone analyzers in such a way that is conducive for nightly auto-checks to occur. Teflon tubing connects from the TS Ozone Port to a tee-connector that splits off between the primary and collocated ozone analyzers. For both the primary and collocated analyzers, there is another tee-connector between the ambient sample line and the line coming from the TS. This connection occurs prior to the particulate filter such that both sampled ambient air and ozone generated by the TS for bi-weekly manual checks both run through the Teflon particulate filter.

NOTE: In order for this system to work, the Vent Port on the TS must be plugged.

1.14.2 Solenoid System

A two-way solenoid is used to allow for zero air to flow to the transfer standard during the automated checks. The valve is only open during the automated check period. Otherwise, it is closed.

An industrial timer is used to determine when the solenoid valve is opened or closed. The timer is checked at each site visit and adjusted if off from the data logger by more than 1 minute.

The two-way solenoid is set to open at 2 minutes prior to the start of the hour in which auto-calibration occurs, and close 2 minutes following the completion of the auto-calibration.

1.14.3 Calibration Program in the 49i Transfer Standard

A calibration program must be set up in the 49i Transfer Standard before the calibration will occur. From the Main Menu, use the ↓ button to scroll to **CALIBRATIONS** and press **ENTER**. From the Calibration Menu, use the ↓ button to scroll to **ZERO/SPAN CHECK** and press **ENTER**.

1.14.3.1 Next Time

The Next Time screen is used to view and set the next zero/precision/span check date and time. Once the initial check is performed, the date and time of the next check is calculated and displayed.

From the Zero/Span Check Menu, use the ↓ button to scroll to **NEXT TIME** and press **ENTER**. Use the → button to select: year, month, day, hour, minutes, or seconds. Use the ↑ or ↓ buttons to increase/decrease the desired value. Set the appropriate date and time and press **ENTER**.

NOTE: At each site visit, the internal clock on the site analyzers and transfer standard should be synced to the time on the data logger.

1.14.3.2 Period Hours

The period Hours screen defined the period or interval between zero/precision/span checks. Periods between 0 and 999 hours are acceptable. To turn the check off, set the period to 0.

From the Zero/Span Check Menu, use the ↓ button to scroll to **PERIOD HR** and press **ENTER**. Use the ← and → buttons to move the cursor left or right, and the ↑ and ↓ buttons to increment or decrement to the desired numeric value. Polk County Air Quality will use a sample period of 24-hours.

1.14.3.3 Zero/Precision/Span Duration

The Zero, Precision and Span Duration Minutes Screen defines how long the desired level is sampled by the instrument. Durations between 0 and 60 minutes are acceptable.

To set the zero air duration, use the ↓ button to scroll to **ZERO DURATION MIN** and press **ENTER**. Use the ← and → buttons to move the cursor left or right, and the ↑ and ↓ buttons to increment or decrement to the desired numeric value. Polk County Air Quality will sample zero air for 15 minutes.

To set the precision duration, use the ↓ button to scroll to **OZ L1 DURATION MIN** and press **ENTER**. Use the ← and → buttons to move the cursor left or right, and the ↑ and ↓ buttons to increment or decrement to the desired numeric value. Polk County Air Quality will sample precision gas for 15 minutes.

To set the span duration, use the ↓ button to scroll to **OZ L2 DURATION MIN** and press **ENTER**. Use the ← and → buttons to move the cursor left or right, and the ↑ and ↓ buttons to increment or decrement to the desired numeric value. Polk County Air Quality will sample span gas for 15 minutes.

1.14.3.4 Zero/Span Averaging Time

The Zero/Span Averaging Time screen allows the user to adjust the zero/precision/span averaging time. This averaging time is used by the analyzer only when performing an automatic check. The analyzer's averaging time is used for all other functions.

From the Zero/Span Check Menu, use the ↓ button to scroll to **ZERO/SPAN AVG SEC** and press **ENTER**. Use the ↑ and ↓ buttons to scroll to **30 SEC** and press **ENTER**.

1.14.4 Communication Settings in Agilaire AirVision Software

The Model 49i communicates with the 8832 ESC data logger via of Modbus through the Ethernet. For an instrument-controlled calibration, the digital inputs must be assigned in AirVision, in order for the instrument to communicate with the logger when a calibration is occurring and when there is a change from one calibration phase to another. See Polk County Air Quality AirVision SOP Section 18 for instructions on programming digital inputs in AirVision software.

1.14.5 Calibration Program in AirVision

A Calibration Program must be set up in AirVision in order for the software to recognize that the instrument is in calibration mode and flags the data with a "C". An Instrument-Controlled Calibration program will be used. An instrument-controlled calibration is initiated by the calibration program set up in the Thermo 49i Transfer Standard, refer to Section 1.14.3. The data logger senses the zero, precision, and span phases through its digital input lines. For each phase, a specific pattern of input control line status is defined. The data logger monitors input control line status and when the specified pattern is met, the corresponding calibration phase is initiated. There is no predefined duration for individual

phases programmed into the AirVision calibration program; each phase will continue until the input line pattern is no longer met. The duration of each phase is determined by the calibration program in the Thermo 49i Transfer Standard, refer to Section 1.14.3. **Polk County uses a 15-minute duration for each desired phase.** At the end of each phase, the concentrations are written into the calibration report. See Polk County Air Quality AirVision SOP Section 18 for instructions on setting up a calibration program in AirVision software.

The specific pattern of input control line status currently in us for Ozone at the Carpenter Site:

- Zero Phase: 30 = on, 31 = off, 32 = off
- Precision Phase: 30 = off, 31 = on, 32 = off
- Span Phase: 30 = off, 31 = off, 32 = on

NOTE: When reading the status inputs from the Model 8832 data logger, the following patterns will be observed:

- Zero Phase: 30&31=0&32=0
- Precision Phase: 30=0&31&32=0
- Span Phase: 30=0&31=0&32

The specific pattern of input control line status currently in us for Ozone at the Sheldahl Site:

- Zero Phase: 28 = on, 29 = off, 30 = off
- Precision Phase: 28 = off, 29 = on, 30 = off
- Span Phase: 28 = off, 29 = off, 30 = on

NOTE: When reading the status inputs from the Model 8832 data logger, the following patterns will be observed:

- Zero Phase: 28&29=0&30=0
- Precision Phase: 28=0&29&30=0
- Span Phase: 28=0&29=0&30

Table 1-1: Measurement Quality Objectives

Ozone Validation Template			
1) Requirement (O ₃)	2) Frequency	3) Acceptance Criteria	Information /Action
CRITICAL CRITERIA-OZONE			
<i>Monitor</i>	NA	<i>Meets requirements listed in FRM/FEM designation</i>	1) 40 CFR Part 58 App C Sec. 2.1 2) NA 3) 40 CFR Part 53 & FRM/FEM method list
<i>One Point QC Check Single analyzer</i>	Every 14 days	< ±7.1% (percent difference) or < ±1.5 ppb difference whichever is greater	1 and 2) 40 CFR Part 58 App A Sec. 3.1 3) Recommendation based on DQO in 40 CFR Part 58 App A Sec. 2.3.1.2. QC Check Conc range 0.005 - 0.08 ppm and 05/05/2016 Technical Note on AMTIC
Zero/span check	Every 14 days	Zero drift < ± 3.1 ppb (24 hr) < ± 5.1 ppb (>24hr-14 day) Span drift < ± 7.1 %	1 and 2) QA Handbook Volume 2 Sec. 12.3 3) Recommendation and related to DQO
OPERATIONAL CRITERIA -OZONE			
Shelter Temperature Range	Daily (hourly values)	20.0 to 30.0° C. (Hourly avg) or per manufacturers specifications if designated to a wider temperature range	1, 2 and 3) QA Handbook Volume 2 Sec. 7.2.2 Generally, the 20-30.0° C range will apply but the most restrictive operable range of the instruments in the shelter may also be used as guidance. FRM/FEM list found on AMTIC provides temp. range for given instrument. FRM/FEM monitor testing is required at 20-30° C range per 40 CFR Part 53.32
Shelter Temperature Control	Daily (hourly values)	< 2.1° C SD over 24 hours	1, 2 and 3) QA Handbook Volume 2 Sec. 7.2.2
Shelter Temperature Device Check	Every 182 days and 2/ calendar year	<± 2.1° C of standard	1, 2 and 3) QA Handbook Volume 2 Sec. 7.2.2
<i>Annual Performance Evaluation Single analyzer</i>	Every site every 365 days and 1/ calendar year within period of monitor operation,	Percent difference of audit levels 3-10 < ±15.1% Audit levels 1&2 < ± 1.5 ppb difference or < ± 15.1%	1 and 2) 40 CFR Part 58 App A Sec. 3.1.2 3) Recommendation- 3-audit concentrations not including zero. AMTIC guidance 2/17/2011 AMTIC Technical Memo
<i>Federal Audits (NPAP)</i>	20% of sites audited in calendar year	Audit levels 1&2 < ± 1.5 ppb difference all other levels percent difference < ± 10.1%	1 and 2) 40 CFR Part 58 App A Sec. 3.1.3 3) NPAP QAPP/SOP
Verification/Calibration	Upon receipt/adjustment/repair/ installation/moving and repair and recalibration of standard of higher level Every 182 day and 2/ calendar year if manual zero/span performed biweekly Every 365 day and 1/ calendar year if continuous zero/span performed daily	All points < ± 2.1 % or < ± 1.5 ppb difference of best-fit straight line whichever is greater and Slope 1 ± .05	1) 40 CFR Part 50 App D 2) Recommendation 3) 40 CFR Part 50 App D Sec 4.5.5.6 Multi-point calibration (0 and 4 upscale points) Slope criteria is a recommendation
<i>Zero Air/Zero Air Check</i>	Every 365 days and 1/calendar year	Concentrations below LDL	1) 40 CFR Part 50 App D Sec. 4.1 2 and 3) Recommendation
Ozone Level 2 Standard			

1) Requirement (O ₃)	2) Frequency	3) Acceptance Criteria	Information /Action
<i>Certification/recertification to Standard Reference Photometer (Level 1)</i>	Every 365 days and 1/calendar year	single point difference < ± 3.1%	1) 40 CFR Part 50 App D Sec. 5.4 2 and 3) Transfer Standard Guidance EPA-454/B-10-001 Level 2 standard (formerly called primary standard) usually transported to EPA Regions SRP for comparison
<i>Level 2 and Greater Transfer Standard Precision</i>	Every 365 days and 1/calendar year	<i>Standard Deviation less than 0.005 ppm or 3.0% whichever is greater</i>	1) 40 CFR Part 50 Appendix D Sec. 3.1 2) Recommendation, part of reverification 3) 40 CFR Part 50 Appendix D Sec. 3.1
(if recertified via a transfer standard)	Every 365 days and 1/calendar year	Regression slopes = 1.00 ± 0.03 and two intercepts are 0 ± 3 ppb	1, 2 and 3) Transfer Standard Guidance EPA-545/B-10-001
Ozone Transfer standard (Level 3 and greater)			
Qualification	Upon receipt of transfer standard	< ±4.1% or < ±4 ppb (whichever greater)	1, 2 and 3) Transfer Standard Guidance EPA-545/B-10-001
Certification	After qualification and upon receipt/adjustment/repair	RSD of six slopes ≤ 3.7% Std. Dev. of 6 intercepts ≤ 1.5	1, 2 and 3) Transfer Standard Guidance EPA-545/B-10-001 1
Recertification to higher level standard	Beginning and end of O ₃ season or every 182 days and 2/calendar year whichever less	New slope = ± 0.05 of previous and RSD of six slopes ≤ 3.7% Std. Dev. of 6 intercepts ≤ 1.5	1, 2 and 3) Transfer Standard Guidance EPA-545/B-10-001 recertification test that then gets added to most recent 5 tests. If does not meet acceptability certification fails
Detection (FEM/FRMs) Noise and Lower Detectable Limits (LDL) are part of the FEM/FRM requirements. It is recommended that monitoring organizations perform the LDL test to minimally confirm and establish the LDL of their monitor. Performing the LDL test will provide the noise information.			
<i>Noise</i>	Every 365 days and 1/ calendar year	≤ 0.0025 ppm (standard range) ≤ 0.001 ppm (lower range)	1) 40 CFR Part 53.23 (b) (definition & procedure) 2) Recommendation- info can be obtained from LDL 3) 40 CFR Part 53.20 Table B-1
<i>Lower detectable limit</i>	Every 365 days and 1/calendar year	≤ 0.005 ppm (standard range) ≤ 0.002 ppm (lower range)	1) 40 CFR Part 53.23 (b) (definition & procedure) 2) Recommendation 3) 40 CFR Part 53.20 Table B-1
SYSTEMATIC CRITERIA-OZONE			
<i>Standard Reporting Units</i>	<i>All data</i>	<i>ppm (final units in AQS)</i>	1, 2 and 3) 40 CFR Part 50 App U Sec. 3(a)
<i>Rounding convention for design value calculation</i>	<i>All routine concentration data</i>	<i>3 places after decimal with digits to right truncated</i>	1, 2 and 3) 40 CFR Part 50 App U Sec. 3(a) The rounding convention is for averaging values for comparison to NAAQS not for reporting individual hourly values.
<i>Completeness (seasonal)</i>	<i>3-Year Comparison</i>	≥ 90% (avg) daily max available in ozone season with min of 75% in any one year.	1,2,3) 40 CFR Part 50 App U Sec 4(b)
	<i>8-hour average</i>	≥ if at least 6 of the hourly concentrations for the 8-hour period are available	1) 40 CFR Part 50 App U 2 and 3) 40 CFR Part 50 App U Sec. 3(b)
	<i>Valid Daily Max</i>	≥ if valid 8-hour averages are available for at least 13 of the 17 consecutive 8-hour periods starting from 7:00 a.m. to 11:00 p.m	1) 40 CFR Part 50 App U 2,3) 40 CFR Part 50 App U Sec. 3(d)
<i>Sample Residence Time Verification</i>	Every 365 days and 1/calendar year	≤ 20 Seconds	1) 40 CFR Part 58 App E, Sec. 9 (c) 2) Recommendation

1) Requirement (O ₃)	2) Frequency	3) Acceptance Criteria	Information /Action
			3) 40 CFR Part 58 App E, Sec. 9 (c)
<i>Sample Probe, Inlet, Sampling train</i>	<i>All sites</i>	<i>Borosilicate glass (e.g., Pyrex®) or Teflon®</i>	1) 40 CFR Part 58 App E, Sec. 9 (a) 2) Recommendation 3) 40 CFR Part 58 App E, Sec. 9 (a) FEP and PFA have been accepted as an equivalent material to Teflon. Replacement or cleaning is suggested as 1/year and more frequent if pollutant load or contamination dictate
<i>Siting</i>	Every 365 days and 1/calendar year	<i>Meets siting criteria or waiver documented</i>	1) 40 CFR Part 58 App E, Sec. 2-6 2) Recommendation 3) 40 CFR Part 58 App E, Sec. 2-6
EPA Standard Ozone Reference Photometer (SRP) Recertification (Level 1)	Every 365 days and 1/calendar year	Regression slope = 1.00 ± 0.01 and intercept < 3 ppb	1, 2 and 3) Transfer Standard Guidance EPA-454/B-10-001 This is usually at a Regional Office and is compared against the traveling SRP
<i>Precision (using 1-point QC checks)</i>	<i>Calculated annually and as appropriate for design value estimates</i>	90% CL CV < 7.1%	1) 40 CFR Part 58 App A 2.3.1.2 & 3.1.1 2) 40 CFR Part 58 App A Sec. 4 (b) 3) 40 CFR Part 58 App A Sec. 4.1.2
<i>Bias (using 1-point QC checks)</i>	<i>Calculated annually and as appropriate for design value estimates</i>	95% CL < $\pm 7.1%$	1) 40 CFR Part 58 App A 2.3.1.2 & 3.1.1 2) 40 CFR Part 58 App A Sec. 4 (b) 3) 40 CFR Part 58 App A Sec. 4.1.3

NOTE: Polk County Air Quality's SOP may specify more stringent requirements for non-critical criteria or more frequent QA procedures than required by the EPA. The operational and systematic criteria listed in the MQO Table are the Federal minimum criteria only.

APPENDIX A-Critical Forms and Field Sheets

- Form 1.....Ozone Primary Standard Certification Worksheet**
- Form 2.....Checklist for Certification of Iowa Ozone Primary Standards against EPA’s Standard Reference Photometer**
- Form 3.....1x6 Averages Worksheet for Certification of Ozone Transfer Standards**
- Form 4.....(1x6) & (6x6) Linear Regression**
- Form 5.....Calibration Field Sheet**
- Form 6.....Calibration Linear Regression**
- Form 7.....Zero/Precision/Span Field Sheet**
- Form 8.....Audit Field Sheet**
- Form 9.....Corrective Action Form**

Form 1-1 – Ozone Primary Standard Certification Worksheet (Cert tab)

Ozone Primary Standard Certification Worksheet					
Std. Ref. Photometer (SRP) ID:			Primary Standard (PS) Serial No:		
PS Make/Model No:			PS Background Coeff. (BC):		
PS Temperature Correction On?			PS Span Coeff. (SC) (ppb):		
PS Pressure Correction On?			Full Scale Range for PS (ppb):		
EPA Cert. Date	SRP (ppb)	Primary Std. (ppb)	Calculations		
			m	i	r^2
			m	i	r^2
			m	i	r^2
			m	i	r^2
			m	i	r^2
		Averages:			

Form 2 – Checklist for Certifications of Iowa Ozone Primary Standards Against EPA Standard Reference Photometer

Terminology:

Standard Reference Photometer (SRP): SRP denotes EPA Region 7’s standard reference photometer which is also known as a level 1 standard.

Primary Standard (PS): Primary lab standard(s) operated by Iowa reporting organizations which are taken to Kansas City and certified against EPA’s Region 7 SRP, also known as a level 2 standard.

RO: Refers to Iowa reporting organizations; specifically Linn County, Polk County, and the State Hygienic Lab.

EPA: Refers to Region 7.

Yes indicates the task has been completed. Each line should be initialed by the person who performed the task, and checked the “Yes” or “No” box. Boxes can be checked or unchecked by clicking on them with the left mouse button.

Prior to RO’s Arrival at EPA:

Yes No The RO will forward their historical data to EPA at least one month in advance of their visit to EPA. (The data will be presented in the “Ozone Primary Standard Certification Worksheet” for uniformity among RO’s, and to facilitate EPA’s review.)
Initials:

Yes No EPA reviews the six most recent certification/recertification days (yellow cells in spreadsheet) to ensure that they match EPA records.
Initials:

Yes No EPA does a cursory review of the calculations for the six most recent certification/recertification days. This involves verifying that dates, slopes, and intercepts from individual runs match EPAs records; and reviewing any averaging of slopes and intercepts.
Initials:

Yes No If the review is satisfactory EPA emails the RO telling them they can bring the PS to Kansas City.
Initials:

When the RO Arrives at EPA:

Yes No EPA confirms that the serial number(s) of the PS(s) have not changed since the last six certification/recertification days.

Initials: _____

Yes No The RO confirms that the PS(s) have not undergone major repairs or adjustments since the last six certification/recertification days.

Initials: _____

Yes No EPA confirms that the span and background coefficients of the PS(s) have not changed since the last six certification/recertification days, and match EPA's records.

Initials: _____

Yes No EPA confirms that the serial number of the SRP has not changed since the last six certification/recertification days.

Initials: _____

Yes No EPA confirms that the SRP has not undergone major repairs or adjustments since the last six certification/recertification days.

Initials: _____

Yes No Prior to taking any measurements, EPA will verify that the top portion of the Cert and ReCert tabs of "Ozone Primary Standard Certification Worksheet" (e.g. info regarding temperature and pressure correction, span and background coefficients, etc.) have been completely filled out.

Initials: _____

Yes No Prior to use of the PS by the RO, the RO will verify that all relevant acceptance criteria (relating to slope, S_m , and S_i) for the new certification/recertification day are met. This can be done by verifying that the "Passes all tests:" cell of the "Ozone Lab Standard Certification Worksheet" evaluates to *TRUE*.

Initials: _____

After Certification/Recertification of Iowa Ozone Primary Lab Standards:

RO Representative (Print): _____

RO Representative Signature: _____ Date: _____

EPA Representative (Print): _____

EPA Representative Signature: _____ Date: _____

Form 3 – 1 x 6 Averages Worksheet for Certification of Ozone Transfer Standards

1x6 Averages Worksheet for Certification of Ozone Transfer Standard

Date:		Primary Standard (PS) Make:	
Operator:		Primary Standard (PS) Model:	
Ambient Temp.:		Primary Standard (PS) Serial No.:	
Barometric Press.:		Transfer Standard (TS) Make:	
Thermometer Ser. No.:		Transfer Standard (TS) Model:	
Barometer Serial No.:		Transfer Standard (TS) Serial No.:	
		Slope (M) of PS Correction Equation:	
		Intercept (I) of PS Correction Equation:	
		Full Scale Range for PS (ppb):	
		TS SC During Certification*:	
		TS BC During Certification in ppb**:	
		Full Scale Range for TS (ppb):	

Target Value	Zero (0 ppb)		50 ppb		90 ppb		200 ppb		350 ppb		450 ppb	
Minute	PS	TS	PS	TS	PS	TS	PS	TS	PS	TS	PS	TS
1												
2												
3												
4												
5												
6												
7												
8												
9												
10												
Average												
Corrected Avg												

Primary Standard	
Lamp V.:	
Ozone V.:	
Volt Check:	
Bench Temp.:	
Bench Lamp Temp.:	
Ozone Lamp Temp.:	
Pressure:	
Cell A Flow:	
Cell B Flow:	

Transfer Standard	
Lamp V.:	
Ozone V.:	
Volt Check:	
Bench Temp.:	
Bench Lamp Temp.:	
Ozone Lamp Temp.:	
Pressure:	
Cell A Flow:	
Cell B Flow:	

Corrected Primary Std O₃ Conc. = 1/M(Indicated Primary Std O₃ Conc. - I)

Form 4 – 6 x 6 Transfer Standard Calibration Linear Regression

Ozone 6 x 6 Calibration Sheet Form 1

Manufacturer: Thermo
 Serial # TS/AS: _____
 Bkgrd Coef: _____
 Ozone Coef: _____
 Serial # PS: _____
 Bkgrd Coef: _____
 Ozone Coef: _____

1st 6 x 6 Calibration Date:									
Level (ppm)	Primary Standard	Transfer Standard	% difference	Slope	Intercept	R ²	Logical	Pass/Fail	
Zero			n/a	#DIV/0!	#DIV/0!	#DIV/0!	#DIV/0!	#DIV/0!	#DIV/0!
0.100			#DIV/0!						
0.200			#DIV/0!						
0.300			#DIV/0!						
0.400			#DIV/0!						
0.500			#DIV/0!						

2nd 6 x 6 Calibration Date:									
Level (ppm)	Primary Standard	Transfer Standard	% difference	Slope	Intercept	R ²	Logical	Pass/Fail	
Zero			n/a	#DIV/0!	#DIV/0!	#DIV/0!	#DIV/0!	#DIV/0!	#DIV/0!
0.100			#DIV/0!						
0.200			#DIV/0!						
0.300			#DIV/0!						
0.400			#DIV/0!						
0.500			#DIV/0!						

3rd 6 x 6 Calibration Date:									
Level (ppm)	Primary Standard	Transfer Standard	% difference	Slope	Intercept	R ²	Logical	Pass/Fail	
Zero			n/a	#DIV/0!	#DIV/0!	#DIV/0!	#DIV/0!	#DIV/0!	#DIV/0!
0.100			#DIV/0!						
0.200			#DIV/0!						
0.300			#DIV/0!						
0.400			#DIV/0!						
0.500			#DIV/0!						

4th 6 x 6 Calibration Date:									
Level (ppm)	Primary Standard	Transfer Standard	% difference	Slope	Intercept	R ²	Logical	Pass/Fail	
Zero			n/a	#DIV/0!	#DIV/0!	#DIV/0!	#DIV/0!	#DIV/0!	#DIV/0!
0.100			#DIV/0!						
0.200			#DIV/0!						
0.300			#DIV/0!						
0.400			#DIV/0!						
0.500			#DIV/0!						

Section 1: Ozone
Revised: February 17, 2023
Revision Number: 27

5th 6 x 6 Calibration Date:								
Level (ppm)	Primary Standard	Transfer Standard	% difference	Slope	Intercept	R ²	Logical	Pass/Fail
Zero			n/a	#DIV/0!	#DIV/0!	#DIV/0!	#DIV/0!	#DIV/0!
0.100			#DIV/0!					
0.200			#DIV/0!					
0.300			#DIV/0!					
0.400			#DIV/0!					
0.500			#DIV/0!					

6th 6 x 6 Calibration Date:								
Level (ppm)	Primary Standard	Transfer Standard	% difference	Slope	Intercept	R ²	Logical	Pass/Fail
Zero			n/a	#DIV/0!	#DIV/0!	#DIV/0!	#DIV/0!	#DIV/0!
0.100			#DIV/0!					
0.200			#DIV/0!					
0.300			#DIV/0!					
0.400			#DIV/0!					
0.500			#DIV/0!					

Average Slope:	#REF!
----------------	-------

Average Intercept:	#REF!
--------------------	-------

Standard Deviation Sm Equation 5 (SOP) :	#REF!	HAS TO BE LESS THAN 3.7%
--	-------	--------------------------

Quantity Si Equation 6 (SOP):	#REF!	≤ 1.5 PPB
-------------------------------	-------	-----------

#REF! #REF! #REF!

#REF! #REF! #REF!

One test that does not appear on this spreadsheet involves a situation where a 6x6 has already been done on the Trans. Std., and a new 1x6 is carried out. Before the earliest 1x6 is replaced with the latest 1x6, p3-3 of the 2009 Draft document on Trans. Stds. requires that the slope of the new est 1x6 be within ± 5% of the average slope for the 6x6. (It is not really necessary to add this calculation to the spreadsheet, because it can easily be done by hand.) If you pass that test you can replace the earliest 1x6 with the 1x6 just done, compute a new average slope, average y intercept, a new Sm and a new Si, and a new correction equation.

Form 5 – Calibration Field Sheet

Ozone Calibration Sheet
Routine Site Information

Date/Time	
Operator	
Analyzer Serial #	
Date of Last Calibration	
TS Serial #	
Date of Last Calibration	
Zero Air Serial #	
Date of Last Annual Maintenance	
Reading (ppm)	
Ambient Time:	

Site _____
Diagnostic Check (Site Analyzer)

Alarm	Value	Corrective Action
Voltages		
Bench Temp (5 – 50°C)		
Bench Lamp (50 – 60°C)		
Pressure (200-1000 mmHg)		
Flow (0.4 – 1.6 LPM)	A B	
Intensities (Hz) (75,000-120,000)	A B	

Precision (~70 ppb)	Ozone	Transfer Standard
Average		
Qualified Average		
%Difference		

- 1) **Zero Air Check** 2) **Level 1 (~ 50 ppb)** 3) **Level 2 (~ 100 ppb)** 4) **Level 3 (~150 ppb)**
Ozonator (%): _____ Ozonator (%): _____ Ozonator (%): _____

	Ozone	TS		Ozone	TS		Ozone	TS		Ozone	TS
ESC:			ESC:			ESC:			ESC:		
Qual. O3			Qual. O3			Qual. O3			Qual. O3		
Drift			% Drift			% Drift			% Drift		

- 5) **Level 4 (~200 ppb)**
Ozonator (%) _____

	Ozone	TS
ESC:		
Qual. O3		
% Drift		

Perform a linear regression analysis on calibration concentrations. All points should fall within ± 2% of full scale of best fit straight line. Use Form 2, Appendix A from Polk County SOP Section 1-Ozone. For Qualified Ozone: use Equation 7 from Section 1.8 –SOP –Ozone.

The Indicated O_3 Concentrations are the readings taken from the data logger during the Calibration.

Current TS (6x6): Slope(m) _____ **Intercept(I)** _____

$$QualifiedO_3 = \frac{1}{m} (IndicatedO_3Concentration - \bar{I})$$

$$\frac{DataLoggerAverages(Y) - QualifiedTSAverage(X)}{QualifiedTSAverage(X)} \times 100 = \% \text{ Difference}$$

Form 6 – Site Analyzer Calibration Linear Regression

Multipoint Verification/Calibration Assessment		Instructions				
Acceptance Criteria: all points within B4% of best fit straight line		1) Select the calibration scale. This does not need to be the FEM approved scale of the instrument (e.g., 500 ppb or 1000 ppb) in B5. It should be the high cal value. The point difference acceptance value in field B6 will be calculated for the values entered in B4 and B5. 2) Place calibration values (X) in orange cells in row 17 3) Enter the conc. values (Y) from the instrument in the green fields. The worksheet allows for 7 values per conc., but you can place only one row of data into the worksheet and delete the data in the other rows. 4) the remainder of the worksheet should automatically calculate the results. 5) Any point result > the point difference acceptance criteria in B6 will turn the boxes and font in rows 28 red. Any percent difference > than value in B4 will turn the boxes and font in rows 29 red. 6) The percent difference estimates are measured using the best fit conc. values and the average of the instrument values for each conc. 7) Any slope greater than the slope acceptance criteria in B7 will turn Slope Box red				
Percentage Acceptance Value	2%					
Calibration Scale (ppb)	250					
Point Difference Acceptance Value (ppb)	1.5					
Slope Acceptance Criteria	.95 - 1.05					
Only values on sheet that can be changed are in colors		Orange				
		Green				
Site: Carpenter						
Date: 2/24/22						
		Zero Concentration	Concentration 2	Concentration 3	Concentration 4	Concentration 5
Calibrator Value (X) (ppb)		0	46.5	100.3	153.5	206.2
Instrument Values (Y) (ppb)		0.5	46.4	100.4	153.5	206.2
Average		0.50	46.40	100.40	153.50	206.20
Best Fit Concentration			46.69	100.40	153.51	206.12
Point Difference (Best fit - Average)			0.29	0.00	0.01	0.08
Percent Difference (Best fit Conc vs. Avg Y values)			-0.63%	0.00%	-0.01%	0.04%
			r	slope (m _i)	intcpt (I _i)	lin reg
			1.0000	0.9983	0.2699	1.000
		X	Y			
		0	0.50			
		46.5	46.40			
		100.3	100.40			
		153.5	153.50			
		206.2	206.20			

X	Y
0	0.50
46.5	46.40
100.3	100.40
153.5	153.50
206.2	206.20

Calibration Information

Instrument Reading (Y)

Calibration Values (X)

$y = 0.9983x + 0.2699$
 $R^2 = 1$

Form 7- Ozone Field Sheet
Ozone Field Sheet

Site: _____

1) Routine Site Information

Date/Time: _____
 Operator: _____
 Analyzer Serial #: _____
 Date of last Calibration: _____
 TS Serial #: _____
 Date of Last Calibration: _____
 Zero Air Serial #: _____
 Last Annual Maintenance: _____
 Station Observations Made (Y or N)
 Changed Filter? (Y or N)
 If "Y" condition filter @ 0.200 ppm ozone for 30minutes
 Sample Line Checked? (Y or N)
 Data logger recording shelter temp? (Y or N)
 TS Internal pressure 10 psi? (Y or N)
 Reading (ppm): _____
 Record Bkgrd Coef: _____
 Record Ozone Coef: _____
 Ambient: _____
 Date Last
 Zero/Prec/SpanCheck _____ Days _____

Make adjustments per service manual

2) Diagnostic Check ALARMS DETECTED:		
Alarm	Value	Corrective Action
Voltages		Consult Manual
Bench Temp (5 – 50°C)		Consult Manual
Bench Lamp (50 – 60°C)		Consult Manual
Pressure (200-1000 mmHg)		Replace pressure transducer
Flow (0.4 – 1.6 LPM)	A	Replace pump Replace flow sensor
	B	
Intensities (Hz) (75,000-120,000)	A	Adjust lamp setting Replace O3 lamp Replace bench detector
	B	
Leak Check (Flow = 0; Pressure <250 mmHg)		Locate leak Replace solenoid valves Replace capillaries

3) Zero Air Check

4) Precision Check (~70 ppb)

5) Span Check (~200 ppb)

Ozonator Level 1 (%): _____
 Prev. Week % Difference: _____

Ozonator Level 2(%): _____
 Prev. Week % Drift: _____

3)	Ozone (Indicated)	T.S. (Actual)	4)	Ozone (Indicated)	T.S. (Actual)	5)	Ozone (Indicated)	T.S. (Actual)
300 sec reading			300 sec reading			300 sec reading		
Qual. O3:			Qual. O3:			Qual. O3:		
Drift:			% Diff.			% Drift:		
If the difference in zero drift between the current indicated and Qualified Actual readings is outside ± 5.1 ppb, invalidate to last 0/span check and re-calibrate.			If the % difference between the current Indicated and Qualified Actual readings is outside 1.5 ppb or ± 7.1% invalidate to last 0/span check and recalibrate.			If the difference in span drift between the current Indicated and Qualified Actual readings is outside ± 7.1%, invalidate to last 0/span check and re-calibrate.		

Qualified Ozone; Use (Equation 7 from section 1.8 –SOP –Ozone),

$$QualifiedTransStdO_3Conc = \frac{1}{m} (IndicatedTransStdO_3Conc - \bar{I})$$

Current (6x6) slope(m) _____ **Intercept(I)** _____

$$\frac{DataLoggerAverages(Y) - QualifiedTransStdO_3Conc(X)}{QualifiedTransStdO_3Conc(X)} \times 100 = \% \text{ Difference}$$

Form 10 – Audit Field Sheet
Ozone Audit Sheet

Site _____

1) Routine Site Information

2) Diagnostic Check (Site Analyzer)

Date/Time	
Auditor	
Audit Standard Serial #	
Date of Last Calibration	
Site Analyzer Serial #	
Date of Last Calibration	
Zero Air Serial #	
Date of Last Annual Maintenance	
Station Observations Made	Y or N
Sample Line Checked	Y or N
Temp. will be recorded on the data logger.	
Is Temperature Probe Operational?	Y or N
TS Internal Pressure =>10 psi	Y or N
Background Coef. (Site Analyzer)	
Ozone Coef. (Site Analyzer)	
Reading (ppm)	

Alarm	Value	Corrective Action
Voltages		
Bench Temp (5 – 50°C)		
Bench Lamp (50 – 60°C)		
Pressure (200-1000 mmHg)		
Flow (0.4 – 1.6 LPM)	A B	
Intensities (Hz) (75,000-120,000)	A B	

3) Zero Air Check

4) Level 2 (6-19 ppb)

5) Level 4 (40-69 ppb)

6) Level 5 (70-89 ppb)

3) Ozonator (%):			4) Ozonator (%):			5) Ozonator (%):			6) Ozonator (%):		
3)	Ozone (Indicated)	A.S. (Actual)	4)	Ozone (Indicated)	A.S. (Actual)	5)	Ozone (Indicated)	A.S. (Actual)	6)	Ozone (Indicated)	A.S. (Actual)
ESC:			ESC:			ESC:			ESC:		
Qual. O3			Qual. O3			Qual. O3			Qual. O3		
Drift			% diff.			% diff.			% diff.		

If the percent difference is outside of 1.5 ppb or ±15.1% for audit levels 1-2, or if the percent difference is outside of ± 15.1% for audit levels 3-10, and there is reason to believe the results are incorrect or not representative of the analyzers performance, the check must be repeated. The cause for the error must be investigated and corrected. An investigation initiated by audit results outside the above limits may require the invalidation of data. Record all information in the site log.

Qualified Ozone: Use Equation 7 from section 1.8 –SOP –Ozone. The Indicated O_3 Concentrations are the readings taken from the data logger during the Audit.

$$QualifiedO_3 = \frac{1}{m}(IndicatedO_3Concentration - \bar{I})$$

Current AS (6x6) slope(m) _____ **Intercept(I)** _____

$$\frac{ESCDataLoggerAverages(Y) - QualifiedASAverage(X)}{QualifiedASAverage(X)} \times 100 = \% \text{ Difference}$$

Form 9 – Corrective Action Form

Polk County Air Quality - Corrective Action Form

To: _____ Polk County Air Quality _____
(position)

From: _____

Copies of completed form to: AQ Supervisor, File

Urgency: Emergency (immediate action needed) Urgent (24 Hr.)
 Routine (7 days) Next scheduled visit Information only

Problem Identification:

Site: _____
System: _____
Date: _____

Description of Problem: _____

Recommended Action: _____

Signature of Initiator: _____ Date: _____

Problem Resolution:

Date of Corrective Action: _____

Summary of Corrective Action: _____

Result of Corrective Action: _____

Signature of Resolver: _____ Date: _____

Signature of QA Officer: _____ Date: _____

Appendix B: Instructions for Using the Ozone Primary Standard Certification Worksheet

Note: The Ozone Primary Standard Certification Worksheet, and following instructions, were developed by the IDNR.

- **Terminology:**

Standard Reference Photometer (SRP): SRP denotes EPA Region 7's standard reference photometer, also known as a level 1 standard.

Primary Standard (PS): These are known as level 2 standards. PS denotes the primary lab standard(s) operated by Iowa reporting organizations which are taken to Kansas City and certified against EPA's Region 7 SRP.

Certification: (as opposed to recertification) is defined as 6 separate comparisons on 6 separate consecutive, or near consecutive, calendar days. Certification is required for any of the following conditions: for new primary standards, or primary standards being returned to EPA for certification for the first time after substantive repairs or adjustments, those that have had their span or background coefficients changed since the last EPA certification or recertification, or when the acceptance criteria described below (for slope within +/-5%, S_m , and S_i) are not met.

Recertification Day: is a day with three recertification runs. (Note that the time interval between two consecutive recertification days can be, and typically will be, about a year.) Recertification can be done more quickly and is a less comprehensive procedure.

A certification or recertification run consists of 7 points, a zero point and six upscale values.

A slope and intercept is obtained for each certification or recertification run (the Primary Standard readings are the Y coordinates; the SRP readings are the X coordinates).

The slopes and intercepts associated with each run on a recertification day are averaged to give the slope and intercept for the recertification day.

- **Intro and General Outline of Procedure:**

This spreadsheet is to be used while the primary standard is compared to Region 7's standard reference photometer (SRP). The comparison concentrations from the EPA certification letter will be used to correct the raw output of the primary standard to better match the SRP. One reason for correcting the primary standard values is if the need ever arises to switch from the primary PS to a back-up PS. If the two primary standards were certified at opposite ends of the EPA's acceptable limits, the portable transfer standards might lose their certification as a result of the transition between primary standards.

Ordinarily, the span and background coefficients will never be adjusted on the PS, but their values should be entered on the “Ozone Primary Standard Certification Worksheet” and verified each year. The rare circumstances where the span and background coefficients on the PS might be adjusted are: when a brand new PS is received from the manufacturer, after failure to meet EPA’s acceptance criteria for certification against the SRP, or after major repairs. When either the span or background coefficient of the PS is permanently changed, the current certification will be rendered invalid. To obtain (or regain) certification from EPA in these scenarios, EPA requires 6 separate comparisons on 6 separate consecutive, or near consecutive, calendar days.

The PS will not be corrected by attempting to program the correction equation into its zero and span coefficients. The correction is performed externally using the Excel sheet labeled “1x6 Averages Worksheet for Certification of Ozone Transfer Standard”, which will convert the readings of the PS when the slope and intercept (derived from comparison of the PS against EPA’s SRP) of the PS correction equation are entered into the two cells in the extreme upper right corner.

The formula used by the “1x6 Averages Worksheet for Certification of Ozone Transfer Standard” is:

Corrected PS conc. = $1/M$ (Indicated PS conc. – I). The slope and intercept used in this equation must always involve data from six certification runs, or 6 – X certification runs and X re-certification days. The purpose of the “Ozone Primary Standard Certification Worksheet” is to compute this slope (M) and intercept (I).

- **How the “Ozone Primary Standard Certification Worksheet” Works**

The first tab is labeled “Cert”. As described above, at some point every PS will be certified against the SRP using six different calendar days within a 14-day period. (In this case, data from multiple years is not combined, except in the unlikely and purely coincidental event that the certification is done around the first of the year.) Use the “Cert” tab to enter the results in cases like this, where a “start from scratch” certification occurs. The user enters information and data into cells with a yellow background.

The second tab is labeled “Results”. The purpose of this tab is to aggregate results of multiple certification runs and recertification days, and perform acceptability tests required by EPA. The first time the worksheet is opened, only summary data derived from the “Cert” tab is shown. In the year following a “start from scratch”, EPA may choose to recertify the PS by only doing three recertification runs on a single day. Pressing the “Control” key + “r” will run a macro that creates a new tab labeled “Recert 1”. Once results of the comparison have been entered into the “Recert 1” tab, they will automatically be summarized in row 8. The Recertification number (“ReCert#”) is shown in column A. Note that rows pertaining to the initial certification are shown with blue highlighting, while the rows pertaining to the recertification are shown in green highlight. Since the numerical values and test results are entirely auto-filled and automated, nothing should be manually entered on this tab.

The “ReCert 1”, “ReCert 2”, and “ReCert 3”, etc. tabs follow the Cert tab in terms of color highlighting (i.e. yellow for user entered cell content).

A few cautions should be observed when using the spreadsheet:

All cells designed to receive user entered data or information are highlighted yellow. Entries in any other location may cause the spreadsheet to malfunction. Some cells are locked so they cannot be edited. With respect to those that are not locked, do not add or remove tabs, rows, columns, cells or formulas (except by use of the macro discussed above, and the “WipeAllData” macro discussed below).

The “ReCert” macro (“Control” key + “r”) should be run only once each year. Proceeding in this way, the completed ReCert sheets (“ReCert 1”, “ReCert 2”, and “ReCert 3”, etc.) will appear in chronological order (with the year increasing as the number at the end of the tab name increases). If the ReCert macro is run multiple times to generate “ReCert” sheets for future years, the completed sheets must appear in the workbook in chronological order, or else the formulae on the “Results” tab will be incorrect, and produce spurious results.

- **Definition of Terms on the Cert Tab, and ReCert 1, 2, 3, ... Tabs:**

See above for definitions of SRP and PS.

PS Make/Model No: The manufacturer and manufacturer’s model number of the primary standard (for example, Thermo 49i-PS).

PS Temperature Correction On? Indicate “Yes”, “No”, or “Not Applicable”. This refers to the temperature correction or compensation feature found on some primary standards.

PS Pressure Correction On? Indicate “Yes”, “No”, or “Not Applicable”. This refers to the pressure correction or compensation feature found on some primary standards.

PS Span Coeff. (SP): is the span coefficient for the primary standard when it is certified against the SRP, and used during the forthcoming ozone season.

PS Background Coeff. (BC) (ppb): is the background coefficient for the primary standard when it is certified against the SRP, and used during the forthcoming ozone season.

Full Scale Range for PS (ppb): is the full scale range for the primary standard. If the full scale range was 500 ppb at the time the primary standard was compared to EPA Region 7’s standard, and the “6x6” comparison performed by an Iowa Reporting Organization only uses a 250 ppb range, the full scale range for the primary standard is still 500 ppb.

EPA Cert. Date: This appears on the Cert tab. It is the date of a “6x7” run, where the primary standard is compared once against the SRP at zero and six non-zero concentration levels. On ReCert 1, 2, 3, ... Tabs the analogous column heading is **EPA ReCert. Date**, which is the date when three recertification runs are done.

SRP (ppb): Each cell below this heading represents the average of 10 readings from the SRP.

Primary Std. (ppb): Each cell below this heading represents the average of 10 readings from the primary standard.

m (lower case): On the Cert tab, m is the slope of a “1x7” run where the primary standard is compared once against the SRP at zero and six non-zero concentration levels. On the ReCert tab, m is the average of all the slopes for a particular recertification day. Note that the m values from both the Cert and ReCert tabs are automatically transferred to the Results tab, into the m column. The slope of a single “1x7” run on the ReCert tab, is simply designated with the word “Slope” instead of m, because these values are not transferred to the Results tab.

i (lower case): On the Cert tab, i is the “Y intercept” of a “1x7” run where the primary standard is compared once against the SRP at zero and six non-zero concentration levels. On the ReCert tab, i is the average of all the “Y intercepts” for a particular recertification day. Note that the i-values from both the Cert and ReCert tabs are automatically transferred to the results tab, into the i column. The “Y intercept” of a single “1x7” run on the ReCert tab, is simply designated with the word “Intercept” instead of i, because these values are not transferred to the Results tab.

r²: is the “r-squared value” (Pearson product moment correlation coefficient). **Note:** this number is not used as acceptance criteria, but may be useful in trouble shooting.

- **Definition of Terms on the Results Tab:**

Recert #: This number is automatically entered and corresponds to the number of recertification days following the initial certification, as well as the number in the tabs labeled “ReCert 1”, “ReCert 2”, “ReCert 3”, etc.

S_m OK? The quantity S_m is the standard deviation of the slopes from the six most recent certification/recertification days, divided by their average slope. (Note that this test involves only six certification/recertification days.) The cells in this column will show TRUE if S_m is ≤ 3.7%.

S_i OK? The quantity S_i is defined as the standard deviation of the Y intercepts from the six most recent certification/recertification days. (Note that this test involves only six certification/recertification days.) The cells in this column will show TRUE if S_i is ≤ 1.5 (ppb).

New m OK? The cells in this column will show TRUE if the slope from the most recent recertification day is within 5% of the average slope from the six most recent certification/recertification days (that have already passed the S_m and S_i test discussed above). Note that this test involves seven certification/recertification days.

Passes all tests: The cells in this column will evaluate to TRUE only if S_m, and S_i meet acceptance criteria, and **New m OK?** evaluates to true. If all 3 tests pass, the slope and intercept for the new certification/recertification day is substituted for the slope and intercept for the oldest of the six most recent certification/recertification days, to compute M and I described below.

M (upper case): is the average of the slopes from the six most recent certification/recertification days that have passed all tests. This is the slope used in the Primary Standard correction equation. If either S_m or S_i fail EPA acceptance criteria, or **New m OK?** evaluates to FALSE, M will not be shown.

I (upper case): is the average intercept from the six most recent certification/recertification days that have passed all tests. This is the intercept used in the Primary Standard correction equation. If either S_m or S_i fail EPA acceptance criteria, or **New m OK?** evaluates to FALSE, I will not be shown.

- **Re-Setting the Spreadsheet**

Pressing the “Control” key + “w” will run a “WipeAllData” macro that clears all the data in the Cert and Results tabs, and deletes tabs labeled “ReCert 1”, “ReCert 2”, “ReCert 3”, etc. (A warning screen appears in the event this key combination is hit accidentally.) This macro can be used in the event that EPA decides, for whatever reason, to do a “start from scratch” certification (i.e. 6 separate comparisons on 6 separate consecutive, or near consecutive, calendar days within a 14-day period).

Appendix C: Instructions for Using the 1x6 Averages Worksheet for Certification of Ozone Transfer Standards

Note: The 1x6 Averages Worksheet for Certification of Ozone Transfer Standards and the following instructions, were developed by the IDNR.

- **Definition of key terms from upper right block:**

Slope (M) of PS Correction Equation: is obtained from the “Results” tab of the “Ozone Primary Standard Certification Worksheet”. Use values from the column labeled with an upper case M (not lower case m), regardless of whether the EPA performed a 3x7 or 6x7 certification of the primary standard.

Intercept (I) of PS Correction Equation: is obtained from the “Results” tab of the “Ozone Primary Standard Certification Worksheet”. Use values from the column labeled with an upper case I (not lower case i), regardless of whether the EPA performed a 3x7 or 6x7 certification of the primary standard.

Full Scale Range for PS (ppb): is the full scale range for the primary standard. If the full scale range was 500 ppb at the time the primary standard was compared to EPA Region 7’s standard, and the “6x6” comparison performed by Polk County only uses a 250 ppb range, the full scale range for the primary standard is still 500 ppb.

TS SC during Certification: the span coefficient for the transfer standard during certification as well as when it’s used in the field. Span coefficients are typically near 1.

TS BC during Certification in ppb: the background coefficient for the transfer standard during certification as well as when it’s used in the field. Background coefficients are typically near 0.

Full Scale Range for TS (ppb): is the full scale range for the transfer standard.

- **Definition of key terms from middle block:**

Primary Std.: Enter raw (uncorrected) 5 minute averages from the LCD display of the primary standard (or its analog or digital outputs) in this column.

Transfer Std.: Enter raw (uncorrected) 5 minute averages from the LCD display of the transfer standard (or its analog or digital outputs) in this column.

Average: This row simply averages the ten “one minute” averages for each column. If a data logger is used to obtain a ten minute average, that average from the data logger can be inserted into this row with the preceding 10 rows left blank.

Corrected Average: The ten minute averages from the primary standard are corrected using the “Primary Standard Correction Equation” indicated at the bottom of the spreadsheet. The ten minute averages for the transfer standard are simply repeated (unchanged). The averages from these rows should be entered into Form 3 – “6 x 6 Transfer Standard Calibration Linear Regression” in the column labeled “Primary Standard”.

- **Procedure:**

This worksheet is used for comparison of the transfer standard to the primary standard during each individual 1x6 run. The corrected primary standard ten minute averages, and uncorrected transfer standard ten minute averages, are taken from this worksheet and transferred to Form 3 – “6 x 6 Transfer Standard Calibration Linear Regression”.

Appendix D: EPA Memo on Addition of a Nafion Dryer to UV Analyzers



UNITED STATES ENVIRONMENTAL PROTECTION AGENCY
RESEARCH TRIANGLE PARK, NC 27711

OFFICE OF
AIR QUALITY PLANNING
AND STANDARDS

February 19, 2021

MEMORANDUM

SUBJECT: Use of Nafion Dryers for Ultraviolet (UV) Ozone Analyzers

FROM: Kristen Benedict, Group Leader
Air Quality Assessment Division, Ambient Air Monitoring Group

TO: EPA Regional Air Monitoring Contacts

In 2017, the Ambient Air Monitoring Group (AAMG) of the Office of Air Quality Planning and Standards (OAQPS) approved a request to add Nafion™ dryers to the ozone sampling lines at select Clean Air Status and Trends Network (CASTNET) sites. EPA's 2017 approval applied only to the CASTNET network and the addition of a Nafion™ dryer upstream of the ozone analyzer inside the monitoring station. The request was made because analyzer noise and slowed response was observed. The CASTNET ozone network uses ultraviolet (UV)-based ozone analyzers that do not include a dryer for humidity control as part of the Federal Equivalent Method (FEM) approval.

EPA has received additional inquiries from other monitoring agencies seeking the approved use of Nafion™ dryers as a means of addressing UV-based ozone measurement issues due to the presence of water vapor. In considering the request, the Office of Research and Development (ORD) and the AAMG have determined that this is not a request for modification to UV-based FEM designations, but a decision regarding the use of acceptable sampling probe material as discussed in 40 CFR part 58 Appendix E. The EPA has concluded that the addition of Nafion™ as part of the sampling line represents a suitable "equivalent" material per Section 9 of Part 58, Appendix E and that there is no evidence of significant loss of ozone in Nafion™ systems. Nafion™ has been shown to significantly reduce measurement noise, biases, and slow analyzer response times. The use of the Nafion™ may also provide the added advantage of increasing the ozone analyzer's scrubber service life.

EPA is providing this memo on the implementation of a Nafion™ dryer upstream of UV-based ozone FEMs (that do not have an internal Nafion™ dryer) on a nationwide basis.

This not a requirement, but an option for monitoring agencies to gain subsequent approval on the use of Nafion™ by the EPA Regions through review and approval of the monitoring agency's Quality Assurance Project Plan (QAPP) and Standard Operating Procedures (SOPs).

ORD’s recommendations for nationwide use of Nafion™ upstream of UV-based ozone analyzers is provided in EPA report EPA/600/R-20/390, 2020 located here:

https://cfpub.epa.gov/si/si_public_record_Report.cfm?dirEntryId=350170&Lab=CEMM

The document provides an overview of:

- the operating principle of UV-based ozone photometers and interferences;
- characteristics of Nafion™, including 2B Technologies’ Dewline™;
- EPA’s review and 2017 approval of CASTNET’s request, including the Nafion™ assembly;
- Nafion™ dryer issues since the 2017 CASTNET approval; and
- summary and conclusions.

Regarding implementation of a Nafion™ system, EPA recommends that:

- the Nafion™ system be based on CASTNET’s operating and design specifications which are provided in Table 1 and Figure 5 from the attached document and included below, with a minor modification to increase the Nafion™ tubing length from 48 inches to 72 inches;
- ozone calibration gases be introduced at the inlet to the Nafion™ system rather than directly into the ozone analyzer; and
- the Nafion™ dryer and analyzer’s scrubber be replaced annually.

It is important to note that the specifications in Table 1 are not specific to the Thermo 49i and can be applied to other UV-based ozone photometer analyzers if needed.

For questions, you may contact Joann Rice at rice.joann@epa.gov.

Table 1. Design and operating specifications of CASTNET’s Nafion™ Dryer

Parameter	Specification
Tested UV-based ozone analyzer	Thermo 49i FEM (EPA designation EQOA-0880-047)
49i sample flow rate	1.3 Lpm
Nafion™ tube	Perma Pure, Model # MD-110-48P-4
Nafion™ tube length	48 inches (1.2 m)
Nafion™ sample air tube’s ID	0.086” (0.218 cm)
Nafion™ sample air residence time	2.1 seconds
Purge air flow rate	1.3 Lpm (nominal)
Purge air to sample air flow ratio	Approx. 1:1
Purge air inlet filter	Parker – Balston, #9933-05-DQ
Purge air flow control orifice	McMaster-Carr, size 0.010”, Model #6349T42
Vacuum pump	Thomas, Model # 107CA18

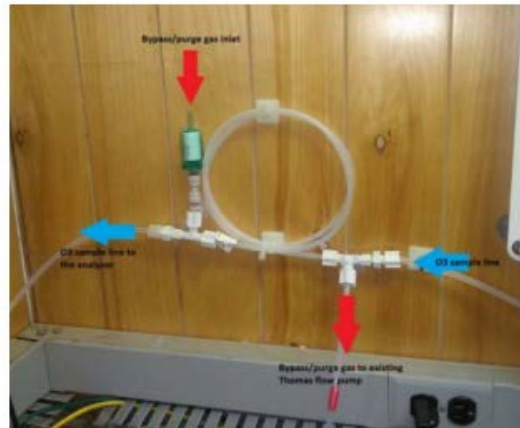

Figure 1. Photograph of CASTNET's Nafion™ assembly showing sample and purge air paths.

