

Right-of-Way Improvement Permit Application



Polk County Public Works
 5885 NE 14th Street
 Des Moines, IA 50313
 Phone: 515-286-3705

Email: publicworks@polkcountyia.gov

Permit Information
 Review Time: Minimum 5 Working Days

Purpose: The purpose of the Right-of-Way Improvement Permit is to improve existing, deep county road ditches, to make them easier to mow for county residents, while still performing their intended function of conveying storm water from the roadway. The minimum existing ditch depth needed to qualify for an improvement permit is shown in the detail below. An Entrance Permit is needed to widen an existing driveway entrance.

Owner Responsibilities: The owner is responsible for the following items: purchasing the corrugated metal pipe and accessories needed to install the pipe as identified by the County, installing the new pipe and making any connections to existing driveway culverts or sump discharges located in the ditch, backfilling, finish grading, seeding, and watering grass/seed to re-establish the ditch.

Owner Information

Owner Name:	Applicant Name:	
Street Address:		
City:	State:	Zip Code:
Phone:	Email:	

Improvement Information (ALL FIELDS REQUIRED)

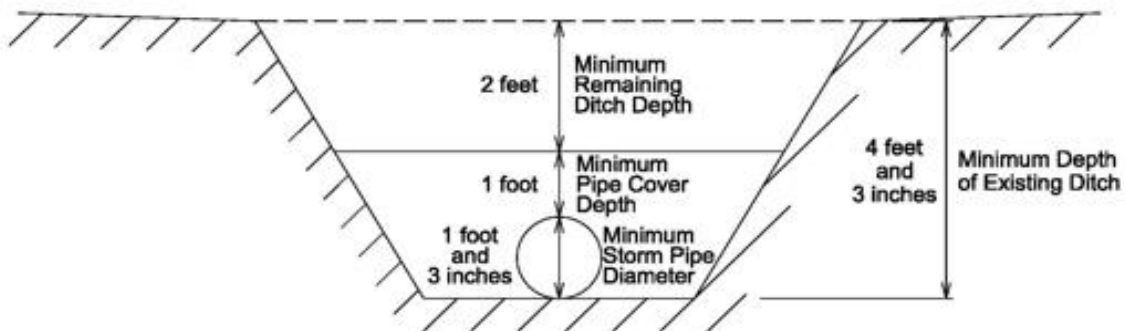

**RIGHT-OF-WAY IMPROVEMENT PERMIT
 MINIMUM DITCH DEPTH
 TYPICAL CROSS SECTION**

Site Improvement Address:
Current Certificate of Insurance on File: <input type="checkbox"/> Yes
Total Width of Ditch Improvement:
Sketch Plan Completed (Applications will NOT be accepted without): <input type="checkbox"/> Yes

I hereby certify that I have read and examined this application and know the information I provided to be true and correct. All provisions of laws and ordinances governing this type of work will be complied with whether specified herein or not. The granting of a permit does not presume to give authority to violate or cancel the provisions of any other state or local laws regulating construction or the performance of construction.

Print Name _____ Signature _____ Date _____

Sketch Plan (Required)

Sketch Requirements (Incomplete sketches will not be accepted)

- Show Driveway
- Ditch Improvements Distance from Property Lines
- Ditch Improvements
- North Arrow

Example Sketch (Do not Sketch in this box)