

COUNTY

ENGINEERING DEPARTMENT

UTILITY

ACCOMMODATION

POLICY

PROCEDURES & STANDARDS

MANUAL

POLK COUNTY SECONDARY
ROAD DEPARTMENT'S
UTILITY ACCOMMODATION POLICY
PROCEDURES AND STANDARDS MANUAL

August, 1978

This Manual has been prepared as the mechanism to implement uniform standards for location, design, and construction of utilities located within right-of-ways of roads and streets under the jurisdiction of Polk County, Iowa.

This Manual is intended to provide minimum requirements and guidelines to utility companies, their engineers, and contractors during planning, design, and construction of their facilities so as to provide a minimum of disruption before, during, and after installation.

The Polk County Engineering Department expresses its appreciation to the utility companies and contractors who cooperated and assisted in the preparation of this Manual.

I hereby certify that this Manual was prepared by me or under my direct personal supervision and that I am a duly registered professional engineer under the laws of the State of Iowa.

Signed

Date

Signed

Date

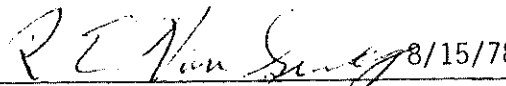
R. E. Van Gundy, P.E. No. 4024
Polk County Engineer

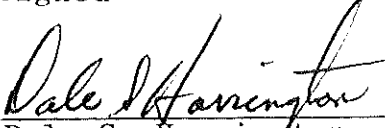
Dale S. Harrington, P.E. No. 6718
Assistant Polk County Engineer

ROLL CALL
FOR ALLOWANCE
AUG 15 1978

Samuel F. Anania	Yea	Nay	<i>h</i>
Tom Whitney	Yea	Nay	<i>h</i>
Richard Brannan	Yea	Nay	
Francis Whitehurst	Yea	Nay	
Jack Bishop	Yea	Nay	
Yea	<u>3</u>	Nay	<u>2</u>
Above tabulation made by <u>mn</u>			

ALLOWED S. O L U T I O N
BY ABOVE BOARD

126-78

August 15, 1978

Moved by Brannan CHAIRMAN Seconded by F. Whitehurst

that the following resolution be adopted:

WHEREAS, the Polk County Engineer has revised the guidelines for Grants and Permits provided for in Chapter 319 and 320 in the 1977 Code of Iowa to provide for more equitable distribution of utility installation, and;

WHEREAS, the requirements for a License and Permit Bond regarding the amount and time, have been modified as follows:

(a) For those major utilities who install mains and laterals in the secondary road right-of-way with permits averaging one per month or more will be required to furnish a \$20,000 annual bond.

(b) For those utilities who install mains and laterals in the secondary road right-of-way, averaging one permit every three months but less than one every month, will be required to furnish a bond in the amount of 10% of the cost of all utility work done within the right-of-way or \$10,000 annual bond, whichever is greater.

(c) For those plumbing contractors who wish to make spot lateral or short longitudinal connections and installations in the secondary road right-of-way, will provide a \$2,000 annual bond.

(d) For those Utilities, Associations, and Contractor's who do not meet (a) through (c) above, bonds will be issued as directed by the County Engineer.

NOW, THEREFORE, BE IT RESOLVED by the Polk County Board of Supervisors that the Polk County Engineer is authorized to initiate the above guidelines for Grants and Permits, for those Utilities, Associations and Contractors who wish to do work within secondary road right-of-way, and be it further resolved that these guidelines be incorporated into "Polk County Secondary Road Department's Utility Accommodation Policies, Procedures, and Standards Manual".

POLK COUNTY BOARD OF SUPERVISORS

Jack Bishop

CHAIRMAN

RECOMMENDED FOR APPROVAL

R. E. Van Duzer
POLK COUNTY ENGINEER

August 15, 1978

R E S O L U T I O N

Moved by Brannon Seconded by Whitcomb
that the following resolution be adopted.

WHEREAS, proper regulation of the location, design, and method for installation, maintenance and adjustment of private and public utility facilities on Polk County's Secondary Road Systems are necessary for safety, public service, and orderly development, and;

WHEREAS, it is the desire of the Polk County Board of Supervisors that such regulations be established and uniformly administered in a manner which will be in the best interest of the Secondary Road System and the public use thereof, with due consideration given to the public service afforded by adequate and economical utility installations, and;

WHEREAS, Section 306.4 of the Code of Iowa states that the Polk County Board of Supervisors has the jurisdictional authority and control over highways which have been designated or established as Secondary Roads, and;

WHEREAS, Section 319 and 320 of the Code of Iowa regulates the use of utilities in Secondary Road right-of-way but does not cover public utilities licensed with the Commerce Commission, and;

WHEREAS, the Civil Division of the Polk County Attorney's Office recommended the development of a "Utility Accommodation Policy" to cover all private and public utility installations similar to Iowa Department of Transportation's Accommodation Policies, and;

WHEREAS, the Polk County Engineering Department, in conjunction with utility companies have developed the "Utility Accommodation Policies, Procedures, and Standards Manual" which establishes uniform regulations and covers initial placement, adjustment, relocation, and replacement of utility facilities, and;

WHEREAS, the Polk County Board of Supervisors recognizes that any such manual which is adopted may create some unforeseen burdens, hardships, or problems and for that reason Polk County reserves the right to vary the provisions of this Manual consistent and harmoniously with the general purpose and intent of the Manual through the exercise of sound and reasonable judgment.

NOW, THEREFORE, BE IT RESOLVED that the Polk County Board of Supervisors adopt the attached Polk County Secondary Road Department's Utility Accommodation Policies, Procedures, and Standards Manual and authorize the Polk County Engineer to administer said Manual.

POLK COUNTY BOARD OF SUPERVISORS

Jack Bishop

 CHAIRMAN

RECOMMENDED FOR APPROVAL

R. E. Hanbury

 POLK COUNTY ENGINEER

ROLL CALL FOR ALLOWANCE AUG 15 1978		
Samuel F. Anania	Yea	Nay <i>ad</i>
Tom Whitney	Yea	Nay <i>sk</i>
Richard Brannan	Yea	Nay
Francis Whitehurst	Yea	Nay
Jack Bishop	Yea	Nay
Yea	<i>2</i>	Nay <i>2</i>
Above tabulation made by <i>JMB</i>		
ALLOWED BY ABOVE VOTE OF BOARD <i>Jack Bishop</i> CHAIRMAN		

TABLE OF CONTENTS

	<u>PAGE</u>
DEFINITIONS	1
INTRODUCTION	7
Chap. 1 SCOPE	7
Chap. 2 APPLICATION	7
Chap. 3 PROVISIONS FOR OCCUPANCY OF RIGHT-OF-WAY	8
Chap. 4 INSPECTION	12
Chap. 5 LIABILITY	13
Chap. 6 LOCATION OF UTILITIES WITHIN ROADWAY RIGHT-OF-WAY	14
Chap. 7 SAW CUTS IN CONCRETE, ASPHALT, AND SEAL COAT STREETS	24
Chap. 8 UTILITY EXCAVATION	26
Chap. 9 BEDDING AND FOUNDATION FOR UTILITIES - PIPE ENVELOPE	29
Chap. 10 BACKFILL AND COMPACTION	33
Chap. 11 UNTRENCHED UTILITY	38
Chap. 12 ENCASEMENT	41

SECTION 1.

DEFINITIONS

AGREEMENT

A contract between Polk County and a utility company relative to utility facility relocation and reimbursement.

APPURTENANCES

Utility facility related features such as vents, drains, manholes, markers, etc.

ARTERIAL HIGHWAY

A general term denoting a highway primarily for through traffic, usually on a continuous route.

AUGERING (BORING)

A means of installing a utility without breaking ground or pavement surface by using the dry bore or low pressure wet bore method which installs the casing and removes the dirt at the same time.

BACKFILL

Replacement of soil in the excavation of a utility service.

BURY

Depth of top of pipe below grade of roadway or ditch.

CABLE

An insulated conductor or combination of insulated conductors.

CARRIER

Pipe or cable directly enclosing a utility transmittant.

CASING

A larger pipe enclosing a carrier.

CLEAR ROADSIDE POLICY

The policy employed by a highway authority to increase safety, improve traffic operation, and enhance the appearance of highways by designing, constructing, and maintaining highway roadsides as wide, flat, and rounded as practical and as free as practical from physical obstructions above the ground such as trees, drainage structures, massive sign supports, utility poles, and other ground mounted obstructions.

COMMUNICATION LINE

A circuit for telephone, telegraph, alarm systems, television transmission, or traffic control purposes.

CONDUIT OR DUCT

An enclosed tubular runway for protecting wires or cables.

CONTROL OF ACCESS

The condition where the right of owners or occupants of abutting land or other persons to access, light, air, or view in connection with a highway is fully or partially controlled by public authority.

FULL CONTROL OF ACCESS

Means that the authority to control access is exercised to give preference to through traffic by providing access connections with selected public roads only by prohibiting crossings at grade or direct private driveway connections.

PARTIAL CONTROL OF ACCESS

Means that the authority to control access is exercised to give preference to through traffic to a degree that, in addition to access connections with selected public roads, there may be some crossings at grade and some private driveway connections.

DIRECT BURIAL

Installing a utility facility underground without encasement.

DRAIN

Appurtenance to discharge liquid contaminants from casings.

ENCASEMENT

Structural element surrounding a pipe.

ENGINEER

The County Engineer of the Secondary Road Department acting directly or through his duly authorized representative, such representative acting within the scope of the particular duties assigned to him, or of the authority given him.

FRONTAGE ROAD

A local street or road auxiliary to and located on the side of an arterial highway for service to abutting property and adjacent areas and for control of access.

GALLERY

An underpass for two or more pipelines.

GRADE SEPARATION

A structure which carries an intersecting highway over or under another highway or railroad.

HIGHWAY, STREET, OR ROADWAY

A general term denoting a public way for purposes of vehicular travel, including the entire area within the right-of-way.

INTERCHANGE

A system of interconnecting highways in conjunction with a grade separation or separations providing for the interchange of traffic between two or more intersecting roadways.

JACKING

A means of installing a utility without breaking ground or pavement surface by forcing utility or encasement through the embankment with the necessary excavation being performed as the jacking progresses.

MANHOLE

An opening in an underground system which workmen or others may enter for the purpose of making installations, inspections, repairs, connections, and tests.

MEDIAN

The portion of a divided highway separating the traveled ways for traffic in opposite directions.

NATURAL GAS DISTRIBUTION SYSTEM

Natural gas mains extending out of municipalities to serve patrons and those mains extending from transmission or feeder mains which are plainly and adequately marked as to location. All lines referred to within this definition shall be constructed to Class 4 standards as defined by the U.S. Department of Transportation, Transportation of Natural Gas and Other Gas by Pipeline; Minimum Safety Standards.

OVERFILL

Backfill above a pipe.

PAVEMENT

That portion of the roadway used for the movement of vehicles, exclusive of shoulders.

PAVEMENT STRUCTURE

The combination of subbase, base course, and surface course placed on a subgrade to support the traffic load and distribute it to the roadbed.

PERMIT

Use and occupancy agreement.

PIPE

A tabular product made as a production item for sale as such. Cylinders formed from plate in the course of the fabrication of auxiliary equipment are not pipe as defined here.

PIPELINE

A carrier system used to transport liquids or gases.

PLOWING

An open narrow trench constructed by continuous cutting (knifing) through the use of a special machine. Normally used by telephone companies in which cable is installed simultaneously.

POLK COUNTY SECONDARY ROAD DEPARTMENT

The Polk County Secondary Road Department as constituted under the laws of Iowa.

POWER LINES

Overhead electrical conductors with supporting poles or structures and underground electrical conductors or cables with the conduit in which they are contained.

PRESSURE

Relative internal pressure in psig (pounds per square inch gauge).

PRIVATE UTILITY FACILITY

Any pole, poleline, pipe, pileline, tileline, sewer line, conduit, conveyor, cable, aqueduct, or any other structure or appurtenance thereof, which is privately owned and dedicated to private use.

PUSHING (DRILLING)

A means of installing a 5" or less diameter utility through a roadway embankment without breaking the road surface by the use of a pushing tool or drill.

PUBLIC UTILITY FACILITY

Any pole, poleline, pipe, pipeline, pipeline company facility, conduit, cable, aqueduct, or any other structure or appurtenance thereof, whether publicly or privately owned, which is used to provide a service to the public or which is directly or indirectly dedicated to public use.

RELOCATION

The removal, rearrangement, reinstallation, protection, or adjustment of a utility facility.

RIGHT-OF-WAY

A general term denoting land, property, or interest therein, usually in a strip, acquired by easement or deed for or devoted to transportation purposes.

ROADWAY

The portion of a highway, including shoulders, for vehicular use. A divided highway has two or more roadways.

RURAL TYPE ROADWAYS

Any roadway other than an urban type roadway.

SERVICE CONNECTION

Any water, gas, power, or communication line which extends from the main or primary utility facility into an adjacent property and which is used to serve that property.

SHOULDER

The portion of the roadway contiguous with the traveled way for accommodation of stopped vehicles for emergency use, and for the lateral support of the base and surface courses.

SIDEFILL

Backfill alongside a pipe.

SLOPE LIMIT OR TOE OF SLOPE

The intersection of the foreslope, and natural ground or ditch bottom.

SPRINGLINE

Top of granular bedding for a utility.

STATE

State of Iowa.

TRAVELED WAY

The portion of the roadway for the movement of vehicles, exclusive of shoulders and auxiliary lanes.

TRENCHED

Installed in a narrow open excavation.

TUNNELING

Installing by the method of tunnel construction. Hand mining is the method most often used.

UNTRENCHED

Installed without breaking ground or pavement surface, such as by augering, jacking, pushing, or tunneling.

URBAN TYPE ROADWAY

A roadway which has as its outside extremities a curb and gutter section.

USE AND OCCUPANCY AGREEMENT

The document by which the highway authority regulates and/or gives approval of the use and occupancy of highway rights-of-way by utility facilities.

UTILITY COMPANY

Any owner or operator of a public utility facility.

UTILITY FACILITY

Either a public utility facility or a private utility facility.

VENT

Appurtenance to discharge gaseous contaminants from casings.

INTRODUCTION

Polk County Secondary Road Department has the responsibility to maintain the rights-of-way of highways under its jurisdiction as necessary to preserve the integrity, operational safety, and function of the highway facility. Since the manner in which utilities cross or otherwise occupy highway rights-of-way can materially affect the appearance, safe operation, and maintenance of the highway, it is necessary that such use and occupancy be authorized and reasonably regulated.

Ch. 1 SCOPE

The regulations are provided for use by utilities for the location, design, and methods for installing, adjusting, accommodating, and maintaining utilities on highway rights-of-way. They do not alter current authority for utilities by the State Commerce Commission.

Polk County recognizes that any policy which is adopted may create some unforeseen burdens, hardships or problems, and for that reason Polk County reserves the right to vary the provisions of these policies, procedures and standards, consistent and harmoniously, however, with the general purposes and intent of the policy, where in the exercise of sound and reasonable judgment, literal application of such policy would defeat the objectives hereinabove set forth.

Ch. 2 APPLICATION

It is the intent of this policy to effectuate and incorporate all of the provisions of the American Association of State Highway Officials on the Accommodation of Utilities on Highway Rights-of-Way, which are not in conflict with the provisions of this policy.

The owner of the utility facility shall assure itself and be responsible that the proposed utility projects meet the applicable requirements of this policy, applicable local, municipal, and county codes, applicable franchise rules and regulations and all applicable laws, regulations and directives promulgated by the Iowa State Commerce Commission, Utilities Division, regulations of the Iowa State Department of Health or any other laws, regulations or standards applicable. These requirements shall include, but not be necessarily limited to, the following:

- 2.1 Electric power and communication facilities should conform with the currently applicable National Electrical Safety Code and Iowa Electrical Safety Code.
- 2.2 Water lines should conform with the currently applicable standards of the American Water Works Association.

2.3 Pressure pipelines should conform with the currently applicable sections of ANSI Standard Code for Pressure Piping of the American National Standards Institute and applicable industry codes, including:

1. Power Piping, ANSI B31.1.0
2. Petroleum Refinery Piping, ANSI B31.3
3. Liquid Petroleum Transportation Piping Systems, ANSI B31.4
4. Gas Transmission and Distribution Piping Systems, ANSI B31.8
5. Department of Transportation, Transportation of Natural Gas and Other Gas by Pipeline; Minimum Safety Standards.

2.4 Liquid petroleum pipelines should conform with the currently applicable recommended practice of the American Petroleum Institute for pipeline crossings under railroads and highways.

2.5 The applicable policy, code, rule, regulation, law, or whatever, which provides the highest degree of protection to the highway and to the public shall supersede all others.

Chap. 3 PROVISIONS FOR OCCUPANCY OF RIGHT-OF-WAY

3.1 PLANS - The utility applicant shall be responsible for the design of the utility facility to be installed within the highway rights-of-way or attached to a highway structure. This includes the measures to be taken to preserve the safe and free flow of traffic, structural integrity of the roadway or highway structures, ease of highway maintenance, appearance of the highway, and the integrity of the utility facility. Except for a service line tap perpendicular to the roadway, plan and profile sheets, along with respective typical sections and details will accompany the permit request showing the type, size and location of the utility and necessary roadway features.

Plan View - Type, Size and Location

- a. Existing roadway, right-of-way, and dimensions; existing entrance locations, bridges, culverts, other utilities and all other pertinent features that the utility may effect.
- b. The proposed utility referenced from the \bar{L} of roadway and the encasement locations and length.

Profile - Size and Location

- a. Profile of existing roadway and ditch bottom.
- b. Profile of proposed utility and encasement.

Details - Type, Size and Location

- a. Typical section of the roadway and the respective utility relation showing type of roadway surface, shoulder, slope, ditch and the right-of-way dimensions.
- b. Typical section of the trench, backfill, bedding and encasement pipe.

3.2 PERMIT STIPULATIONS

In accordance with the current Utility Accommodation Policy, Procedures and Standards Manual (UAPPS):

1. The applicant shall take all reasonable precautions to protect lives and property and save the County harmless of damage or loss on account of such construction.
2. The applicant shall leave the road in as good condition as it was before construction. Any surfacing material removed, covered up or mixed with earth shall be replaced by the applicant at his expense.
3. No excavation shall be made within the limits of the traveled portion of the highway, except as designated on approved plans and shall be completed in one day, tamped and regraded and/or paved as directed by the Polk County Engineer.
4. Applicant shall restore to their original condition or better any improvement removed or damaged during the construction process, such as fences, driveways, power poles, signs, roadways (paved or gravel), structures, etc.
5. Applicant shall place backfill in 6 inch layers, mechanically compacted by tamping or rolling into place using the specified density and standards contained in the UAPPS Manual. Any settlement occurring after backfill has been completed shall be refilled and compacted by applicant or at applicant's expense.
6. No utility facility shall be constructed so as to adversely affect the design, construction, operation, maintenance, or stability of a highway or any proposed or existing highway facility.
7. The utility owner of the facility and its contractor shall be responsible for the care and maintenance of their partially complete work on the right-of-way. Silt basins may be required in possible erosion areas at the permit holders expense.
8. Applicant shall maintain natural drainage at all times.
9. Applicant shall maintain closed ditch from day to day.
10. Applicant shall replace field tile broken by the applicant and maintain existing drainage by rerouting the proposed cable or watermain if necessary.
11. Applicant shall auger or push roadways and driveways as stipulated herein and shall repair all gravel or rock driveways as directed by the Polk County Engineer.

12. Applicant shall definitely close drive trenches and allow access the same day the trench is open.
13. Applicant shall apply "SPECIAL CARE" in working under or near existing surface or subsurface drainage structures (clean all culvert ends allowing free flow).
14. Applicant to locate new underground utilities in accordance with Ch. 6 UAPPS Manual.
15. Applicant to notify all companies having existing utilities located within R.O.W. limits as shown on the plans. Please include telephone numbers of responsible contacts as a part of Special Provisions or General Notes.
16. Applicant to work around and cooperate with all existing utilities.
17. Applicant shall notify all affected consumers one hour in advance before any closing of valves of the existing water system. The Des Moines Water Works must close any valves that are part of their system.
18. Any damage to private property shall be restored to satisfaction of property owner. Written release required.
19. Crawler tractors with lugs will not be allowed on pavement surfaces. Bridging will be required (use planks or old tires).
20. Applicant shall restore all disturbed areas to their original condition or better. Seeding, fertilizing, and mulching will be required as per ISHC Standard Specifications 1977, Section 2601, erosion control.
21. We further assume that normal contractual practices will be adhered to and that performance and maintenance bonds will be required before work is started.
22. Applicant shall make neat saw cuts before making any necessary pavement removals as directed by the Polk County Engineer.
23. Stop boxes are to be installed not more than twelve inches outside of property lines. Meter pits are to be placed inside property lines.
24. All installations shall be placed to not interfere with normal road maintenance operations and applicant shall save the County harmless from all damage to claims on this account.

25. Applicant shall contact the Polk County Engineer one week prior to beginning construction via letter or 48 hours via telephone.
26. Applicant shall attach to the "Grant and Permit" a letter indicating who will own and maintain the proposed improvement and who we will contact if a maintenance problem arises. Also, include acknowledgement that permission is being granted for this installation with the owner completely responsible and liable for the construction, removal, relocation, and future maintenance.
27. Applicant to furnish and install steel casings for use under structures, highways, lakes, and railroad crossings in accordance with Chapter 12 of the UAPPS Manual.
28. The applicant shall conduct his work to cause a minimum interruption of traffic flow. (Do not close road to through traffic.) Proper signing and advance warning will be required as outlined in "IOWA DEPARTMENT OF TRANSPORTATION - HIGHWAY DIVISION 1977 SPECIFICATIONS AND SUPPLEMENTAL SPECIFICATIONS" and "THE MANUAL ON UNIFORM TRAFFIC CONTROL DEVICES FOR STREETS AND HIGHWAYS." All signing will be in compliance with the above and same shall be in place and maintained by the contractor for duration of construction. Iowa DOT 1976 "Construction and Maintenance Traffic Control Handbook" may be used as a guide and supplement to the MUTCD.
29. AS PER RESOLUTION POLK COUNTY BOARD OF SUPERVISORS, DATED August 15, 1978, and as per Chapters 319 and 320, Code of Iowa, 1977, the applicant shall post a LICENSE AND PERMIT BOND with the Polk County Auditor to insure compliance with the above requirements in the amounts as follows:

- (a) for those major utilities who install mains and laterals in the secondary road right-of-way with permits averaging one per month or more will be required to furnish a \$20,000 annual bond;
- (b) for those utilities who install mains and laterals in the secondary road right-of-way, with permits averaging one every three months but less than one every month will be required to furnish a bond in the amount of 10% of the cost of all utility work done within the right-of-way or \$10,000 annual bond, whichever is greater;
- (c) for those plumbing contractors who wish to make spot lateral or short longitudinal connections and installations, in the secondary road right-of-way, will provide a \$2,000 annual bond; and
- (d) for those utilities, associations, and contractors who do not meet "a" through "c" above will issue bonds as directed by the County Engineer.

Ch. 4 INSPECTION

- 4.1 Where utility facilities require relocation or protection because of highway improvements or construction, said relocation shall be performed by the owners of utility facilities in advance of the highway work.
- 4.2 The Engineer shall have authority to decide any questions that arise in reference to the intent of the agreement or permit documents and the compliance therewith, relative to the condition of the highway.
- 4.3 The Engineer shall have the right to approve minor alterations in plans or character of the work, as related to the highway, which may be considered necessary or desirable during the progress of the work to complete satisfactorily the proposed construction. Such alterations shall not be considered as a waiver of any of the conditions of the agreement or permit nor invalidate any of the provisions thereof.
- 4.4 Polk County may appoint inspectors to represent the Engineer in the inspection of all construction (as related to the highway) done within the right-of-way as part of the agreement or permit. An inspector visits the job to keep the Engineer informed as to the progress and manner in which it is being done; also to call the utility company's attention to any infringements of the agreements or permit documents. The inspector will not act as a foreman nor perform other duties for the utility company or their contractor nor improperly interfere with the management of the work. The utility company or their contractor shall furnish the Engineer with every reasonable facility for ascertaining whether the work is being performed in accordance with the agreement or permit documents through the inspector.
- 4.5 All work that involves cutting or removal of pavement, the utility must give the name of the contractor that is going to reconstruct the pavement.
- 4.6 Inspection of Construction Site.
 - A. Inspect before construction.
 - B. During construction.
 - C. The permit holder may call in for a semi-final inspection after backfill, but before seeding or sodding is done.
 - D. Must call in for a final inspection.
 - E. The permit holder will be called if any reshaping or seeding of site needs to be done. The Grant Permit holders must police their own uncompleted construction sites.

- 4.7 If, prior to final inspection, any repairs to the right-of-way are made necessary by the construction or maintenance of a utility facility, the owner shall upon notification immediately make the necessary repairs.
- 4.8 Before final inspection of the condition of the highway, the utility facility owner shall be responsible to remove all unused material or rubbish, resulting from the operation, from the site of the work, and leave the right-of-way in a clean, presentable condition.
- 4.9 Upon notification by the utility facility owner or its authorized representative that the work is completed, the Engineer shall make a prompt inspection of each item of work included in the agreement or permit related to the condition of the highway. If the work completed is not in compliance with the agreement or permit documents, the utility company will be required to correct deficient work. When the condition of the highway is found acceptable, the utility facility owner shall be so notified by the Engineer. All notices required in this paragraph shall be in writing.

Ch. 5 LIABILITY

- 5.1 Where a relocation is to be made by the owner of a utility facility, Polk County shall not be liable for the cost of any change, alteration, or betterment of such utility except as may be provided by law.
- 5.2 Where Polk County is liable by earlier agreements only for costs of relocation required for highway work, Polk County will not pay for any betterment, increase in capacity of such related facilities, or other utility adjustments not required by highway construction. Polk County is entitled to receive credit for accrued depreciation on replaced facilities and the salvage value of any material or parts salvaged and retained or sold by the owner.
- 5.3 The owner of the utility facility shall indemnify and save harmless the County Engineer, Board of Supervisors and Polk County from any and all causes of action, suits at law or in equity, or losses, damages, claims, or demands, and from any and all liability and expense of whatsoever nature for, on account of, or due to the acts or omissions of said owners, officers, members, agents, representatives, employees, contractors or assigns arising out of or in connection with its (or their) use or occupancy of the public highway under a permit or agreement.

Ch. 6 LOCATION OF UTILITIES WITHIN ROADWAY RIGHT-OF-WAY

The following location standards are to serve as a guide for plan development by the utility company. When these standards cannot be met due to unusual circumstances, the utility will so request a waiver from the Polk County Engineer.

Where allowed, longitudinal installations should be located on uniform alignment as near as practicable to the right-of-way line so as to provide a safe environment for traffic operation and preserve space for future highway improvements or other utility installations.

When utilities are placed in the roadway right-of-way, it is desired that each type of utility has a reserved area (horizontal and vertical location) for uniformity. For this reason the following location requirements will be adhered to unless specific authorization or change is provided by the Engineer.

6.1 RURAL AREA

A. OVERHEAD INSTALLATION

1. Location--On and along conventional highways in rural areas, poles and related facilities should be located at or as near as practical to the right-of-way line. As a minimum, the poles should be located outside the clear roadside area for the highway section involved. There is no single minimum dimension for the width of a clear roadside area but, where there is sufficient border space, 30 feet is commonly used as a design safety concept guide. In no event will ground supporting facilities be allowed with the roadway foreslope limits.
2. Where crossings of overhead (aerial) utility facilities are allowed, self-supporting poles or towers, double arming and insulators, and/or dead-end construction should be considered. Where downguys or stub poles are used, they shall be placed in accordance with 6.1 A.1 and shall be as far from the travelled way as practical.

B. UNDERGROUND INSTALLATION

1. Underground longitudinal utility facilities are to be placed as near the right-of-way line as possible. A new facility shall be placed no nearer the roadway than the slope limits, right-of-way width permitting, except at locations where this is not acceptable, such as deep ravines or ditches. The decision as to what is acceptable shall be determined by the Engineer. See Standard U-6.1 for details.

2. With the exception of natural gas distribution systems, the carriers of transmittants which are flammable, corrosive, expansive or unstable, particularly if carried at high pressure, may not be placed longitudinally with the highway within the right-of-way limits.

6.2 SUBURBAN AREA

A. OVERHEAD INSTALLATION

1. Single poles for overhead lines may be located within the right-of-way as far behind the curb line as possible and where feasible behind sidewalks, consistent with the land use adjacent to the right-of-way line. See Standard U-6.4
2. Ground anchors or stub poles should not be placed between a pole and the pavement.

B. UNDERGROUND INSTALLATION

Longitudinal occupancy for proposed utility facilities is to be as near the highway right-of-way line as possible and will not be allowed within the traveled way. See Standard for details U-6.2

6.3 SUBDIVISION ROADWAY

A. GENERAL

In accordance with Polk County Subdivision ordinance, easements for utilities shall be provided along rear or side lot lines particularly where there is adjoining back lots. If utilities such as water and gas cannot cost effectively justify using these rear or side lot easements or for topographic constraints of all utilities, a front lot easement should be established to contain these utilities. When this occurs, all utilities, where possible, should be in the front lot easements. Only when an easement is not possible to obtain, will utilities be allowed in impeding Polk County right-of-way according to established standards. Variances may be required in existing and well-developed areas.

B. CLOSED DITCH - CURB AND GUTTER

See Standard U-6.3 - In no case will the utility be allowed longitudinally under the roadway without express permission from the Engineer.

C. OPEN DITCH

See Standard U-6.2 - In no case will the utility be allowed in the shoulder or under the roadway (longitudinal only).

6.4 UNDERGROUND DEPTH REQUIREMENTS

See Standards U-6.1 through U-6.3

A. MEASUREMENT - The bury is measured as follows:

1. From the ultimate pavement edge except that on a curve, is measured to the lowest pavement edge.
2. When there are curbs and gutters, from the gutter flow line, excluding the local depressions at inlets.
3. The top of curb where installation is to be behind the curb.

B. MINIMUM BURY BELOW FINISHED ELEVATION

See Standard U-6.1 through U-6.3

1. Telephone cable and conduits - 30" minimum, 36" desirable.
2. Gas lines - 36" (3')
3. Electric lines - 48" (4')
4. Water lines - 60" (5') minimum; 72" (6') desirable.
5. Sewer lines - 96" (8'). The vertical clearance between sewer and water lines must be 18" minimum.

6.5 HORIZONTAL CLEARANCE BETWEEN UTILITIES

See Standard U-6.1 through U-6.3 - If the minimum spacing cannot be met as shown in the above standards, the utility being installed will require encasement.

6.6 VERTICAL OVERHEAD CLEARANCE

See Standard U-6.4 - The vertical clearance for overhead utility facilities above all highways and the lateral and vertical clearances from bridges, shall conform with the National Electrical Safety Code 230-24(B), except where greater clearances are required by State law, regulation or policy.

6.7 WATER LINES IN TRENCH WITH OTHER UTILITIES & FACILITIES

- A. Water services may be laid in the same trench with other underground utilities with the exception of sewer pipes, provided such service pipes are laid at least twelve (12) inches in a horizontal plane from other subsurface facilities.
- B. All water mains shall be laid clear of all other underground structures and should not be laid in the same trench with other underground utilities in order to minimize the possibility of water leakage by reason of any movement of such structures or of the mains.
- C. At crossings of mains and services with other underground structures, vertical clearances shall be not less than twelve (12) inches, except for crossing of sanitary sewers in which the vertical clearance is eighteen (18) inches minimum.

6.8 UTILITY ATTACHMENTS TO BRIDGES AND STRUCTURES

- A. Proposals for placing any utility facility on or near bridges (or structures), whether existing or planned, or whether on rural or urban roadways, must be approved by the Polk County Secondary Road Department, prior to the issuance of a permit. The application shall include a detail sketch showing method of attachment and weights of attachment.

Where a pipeline attachment to a bridge (or structure) is to be cased, the casing shall be effectively open or vented at each end to prevent possible build-up of pressure and to detect leakage of gases or fluids.

Where a casing is not provided for a pipeline attachment to a bridge, additional protective measures shall be taken such as the use of extra strength pipe for the carrier.

Where the Secondary Road Department repairs or replaces the bridge (or structure), the utility owner will relocate the utility at no cost to Polk County.

Communication and electric power line attachment shall be suitably insulated, grounded or preferably carried in protective conduit or pipe from the point of exit from the ground to re-entry. Preferably the cable should be carried to a manhole located beyond the backwall of the structure. Carrier pipe and casing pipe shall be suitably insulated from electric power line attachments.

1. Water Mains - Water mains and steam lines belonging to a municipality or a private company serving the municipality may, if the County Engineer considers it desirable, be attached to the bridge structure.
2. Telephone Lines and Cables - Telephone open wire lines, cables, conduits, and multiple cell conduits may be allowed to be attached to bridges (or structures). The fee for such attachment shall be a permit fee of \$50 plus 15¢ per pound weight per foot of utility facility for each foot of the bridge (or structure) length.

$\$50.00 + (\$0.15 \times \text{weight of attachment in pounds per foot} \times \text{length of bridge in feet}) = \text{fee.}$

3. Power Lines - Power lines may be allowed to be attached to a bridge structure. The fee for such attachment shall be the same as for telephone lines in 2. above.
4. No pipeline will be attached to a bridge structure except as allowed in Section 6.8-A.1 and 6.8-A.5.

5. Natural Gas Lines

a. Gas pipe lines in a natural gas distribution system may be attached to a bridge structure longer than 200' under the following conditions:

1. That a utility facility installation below ground level across the bridge (or structure) opening is not feasible.
2. That shut-off valves are placed within 300' of each end of the bridge.
3. That the attachment will not adversely effect the structural capacity of the bridge (or structure).
4. That a lump sum payment is made to the Secondary Roads Department as compensation for attaching gas pipe lines to bridges (or structures) consisting of a \$50 permit fee plus the following:

2" gas main at	\$0.75 per foot length of bridge
3" gas main at	\$1.50 per foot length of bridge
4" gas main at	\$2.25 per foot length of bridge
5" gas main at	\$3.00 per foot length of bridge
6" gas main at	\$4.20 per foot length of bridge
7" gas main at	\$6.45 per foot length of bridge
8" gas main at	\$7.75 per foot length of bridge

For other sizes than given above, the rate shall be based on 15¢ per pound foot of pipe for each foot of bridge length.

- b. The owner of the utility facility shall provide an indemnity bond to be executed either by itself or by a responsible bonding company, at the Polk County Engineer's option, in an amount equal to twice the replacement cost of the bridge (or structure). The indemnitor under such bond shall, in the event of damage to the bridge (or structure) from the explosion of or fire from the gas pipeline attached to such bridge (or structure) resulting from any cause whatsoever, indemnify the Secondary Road Department against all loss or damage to it therefrom, including the expense of repairing or replacing the bridge (or structure) and the cost of alternate highway facilities for traffic during the period of such bridge (or structure) repair or replacement. Such indemnity bond shall be kept in full force and effect as long as the gas pipeline is attached to such highway bridge (or structure). The amount of bond may be reviewed by the Polk County Engineer and adjustments required to reflect changes in construction costs.
- c. The method of attachment and the replacement of the pipeline must have the approval of the Polk County Engineer, and the applicant shall agree to all applicable conditions and stipulations.

6. Utility Facilities on Proposed New Structures

- a. Owners of utility facilities proposing to place utility facilities on structures that are in the planning stage will pay in advance the additional cost occasioned by the increased design time, inspection, strength of the bridge (or structure), and for the attachment weight in accordance with the fees set out above for natural gas pipelines.
 - b. Paragraphs "a" and "b" of 5 shall also apply to natural gas lines on proposed new construction.
7. A permit allowing a utility facility owner the privilege to attach its facilities to a highway structure does not constitute any permanent right for such attachment. The removal, remodeling or relocation of the attachment shall be accomplished by the utility facility owner promptly and at no cost to Polk County.
8. Unless specifically authorized by the Polk County Engineer, maintenance of the attachment will not be performed from the roadway.

TYPICAL CROSS SECTION - RURAL

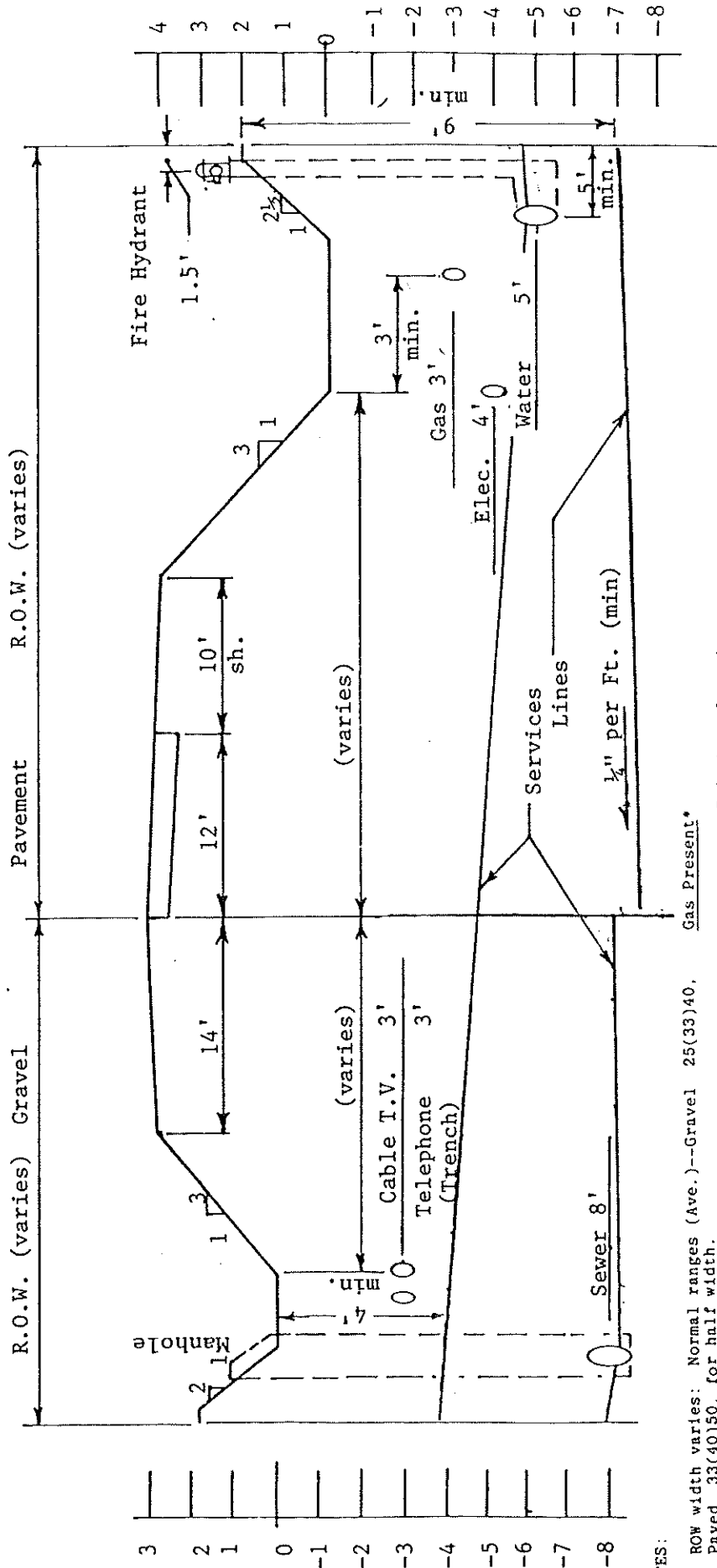

NOTES:

1. ROW width varies: Normal ranges (Ave.)--Gravel 25(33)40. Paved 33(40)50, for half width.
2. Unless otherwise provided/approved, and all utilities are buried: Telephone and sanitary sewer shall be placed on the side of the road of the odd numbered addresses (east and south); water, gas, and electric shall be placed on the even numbered side of the road (west and north).
3. Telephone and electric cables shall be placed at the toe of the foreslope or at: 29' from f (graveled road), or 37' (paved road), whichever is closer to the centerline. If plowing is used, telephone line may be allowed to be installed 18" in from edge of shoulder on gravel roads only.
4. Sanitary sewer and watermain shall be placed at the toe of backslope (or in the backslope if necessary to maintain minimum separation requirements).
5. If insufficient ROW exists to accommodate utility locations, additional easements must be provided.
6. Installation of electric, telephone, and T.V. cables in a joint trench(s) is encouraged. The following priorities will be used for location:

Gas Present*

All Joint @ Telephone Location
 Electric & Telephone @ Telephone Location
 T.V. and Telephone @ Telephone Location
 Electric and T.V. @ Electric Location

Gas Absent*

All Joint @ Electric Location
 Electric and Telephone @ Electric Location
 Electric and T.V. @ Electric Location
 T.V. and Telephone @ Electric Location

*Under current policies, Gas mains are not being extended to all new areas. It will therefore be necessary for this department to be advised whether or not gas service is or will be made available.

Standard U-6.1		Polk County
Underground Utility locations in Rural Roadways		
Rec'd	<i>Bob L. Herring</i>	
8/14/78	Asst. Co. Engr	
Approved	<i>R.E. Alan Gandy</i>	
8/15/78	Polk Co. Engr. P.E. No.	

TYPICAL CROSS SECTION - URBAN

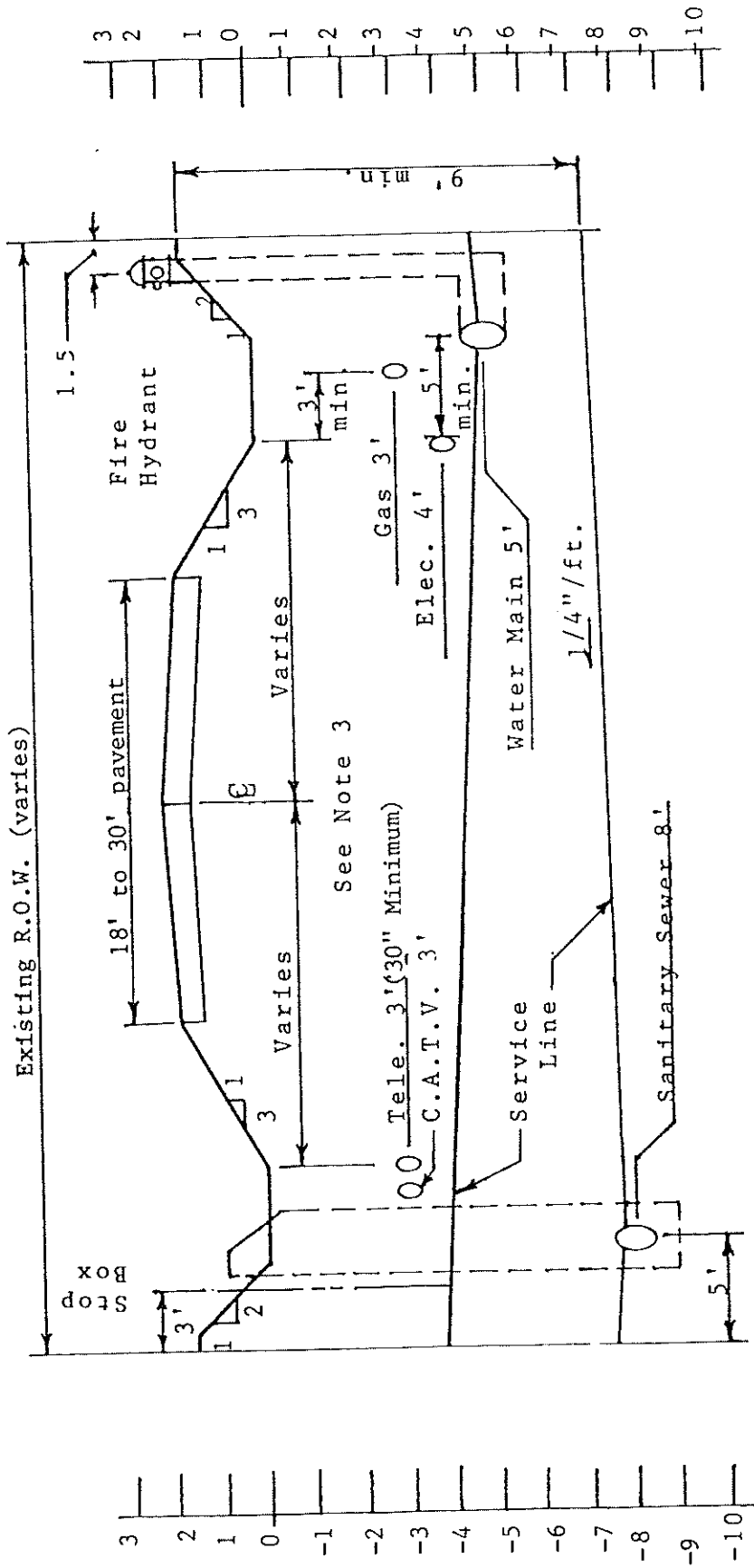

NOTES:

1. ROW width varies: Normal Range (Ave.)--40, (50), 66.
2. Unless otherwise provided/approved, and all utilities are buried: Telephone and sanitary sewer shall be placed on the side of the road of the odd numbered addresses (east and south); water, gas, and electric shall be placed on the even numbered side of the road (west and north).
3. Telephone and electric cables shall be placed at the toe of the foreslope or at: 20' from centerline whichever is closer to centerline.
4. Sanitary sewer and watermain shall be placed at the toe of backslope (or in the backslope if necessary to maintain minimum separation requirements).
5. If insufficient ROW exists to accommodate utility location, additional easements must be provided.
6. Installation of electric, telephone, and T.V. cables in a joint trench(es) is encouraged. The following priorities will be used for location:

Gas Present*

All Joint @ Telephone Location
 Electric & Telephone @ Telephone Location
 T.V. and Telephone @ Telephone Location
 Electric and T.V. @ Electric Location

Gas Absent*

All Joint @ Electric Location
 Electric and Telephone @ Electric Location
 Electric and T.V. @ Electric Location
 T.V. and Telephone @ Electric Location

*Under current policies, gas mains are not being extended to all new areas. It will therefore be necessary for this department to be advised whether or not gas service is or will be made available.

Standard U-6.2	Polk County
Underground Utility Locations in Suburban Areas - Open Ditch	
Rec'd 8/14/78	<i>Robert D. Harrington</i> ASST. CO. ENGR.
Approved 8/15/78	<i>R. E. Allen</i> Polk Co. Engr. P.E. No.

TYPICAL CROSS SECTION - Curb & Gutter

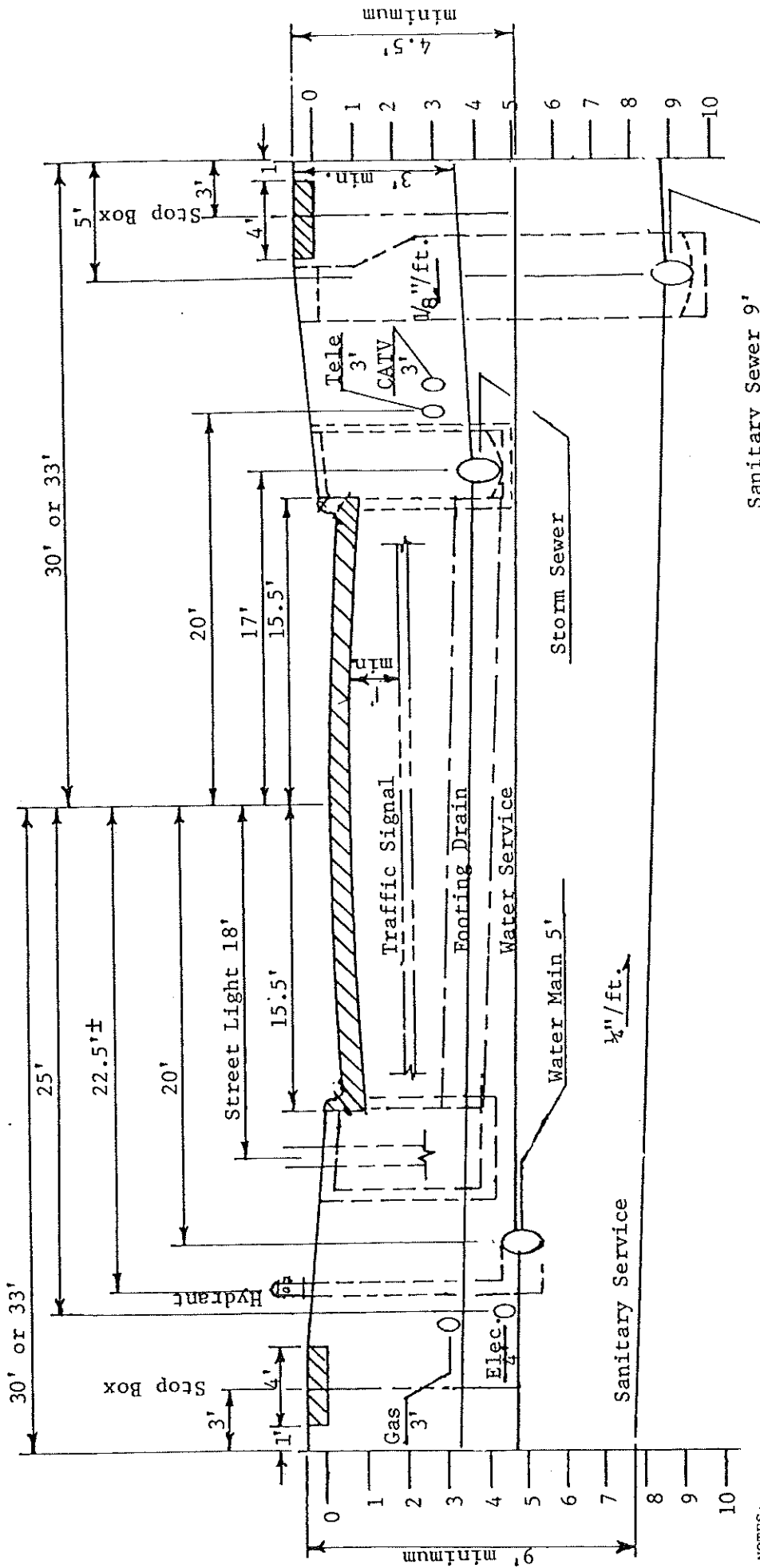

NOTES:

1. ROW width varies: Normal ranges (average) -- 60(66)80
2. Unless otherwise provided/approved, and all utilities are buried: Telephone and sanitary sewer shall be placed on the side of the road of the odd numbered addresses (east and south); water, gas, and electric shall be placed on the even numbered side of the road (west and north).
3. If insufficient ROW exists to accommodate utility locations, additional easements must be provided.
4. Installation of underground electric, telephone, and TV cables along rear lot lines is encouraged. Where this is not practicable, para 5 shall prevail.
5. Installation of electric, telephone, and TV cables in a joint trench(s) is encouraged. The following priorities will be used for location:

Gas Present*

- All Joint @ Telephone Location
- Electric & Telephone @ Telephone Location
- TV and Telephone @ Telephone Location
- Electric and TV @ Electric Location

Gas Absent*

- All Joint @ Electric Location
- Electric and Telephone @ Electric Location
- Electric and TV @ Electric Location
- TV and Telephone @ Electric Location

*Under current policies, gas mains are not being extended to all new areas. It will therefore be necessary for this department to be advised whether or not gas service is or will be made available.

Standard U-6.3		Polk County	
Underground Utility Locations in Subdivision Roadway - Closed Ditch.			
Effective	Rec'd	<i>Dele S. Herring</i>	
	8/14/78	ASST. Co. ENGR.	
Effective	Approved	<i>R. E. Herring</i>	
	8/15/78	Polk Co. Engr. P.E. No.	

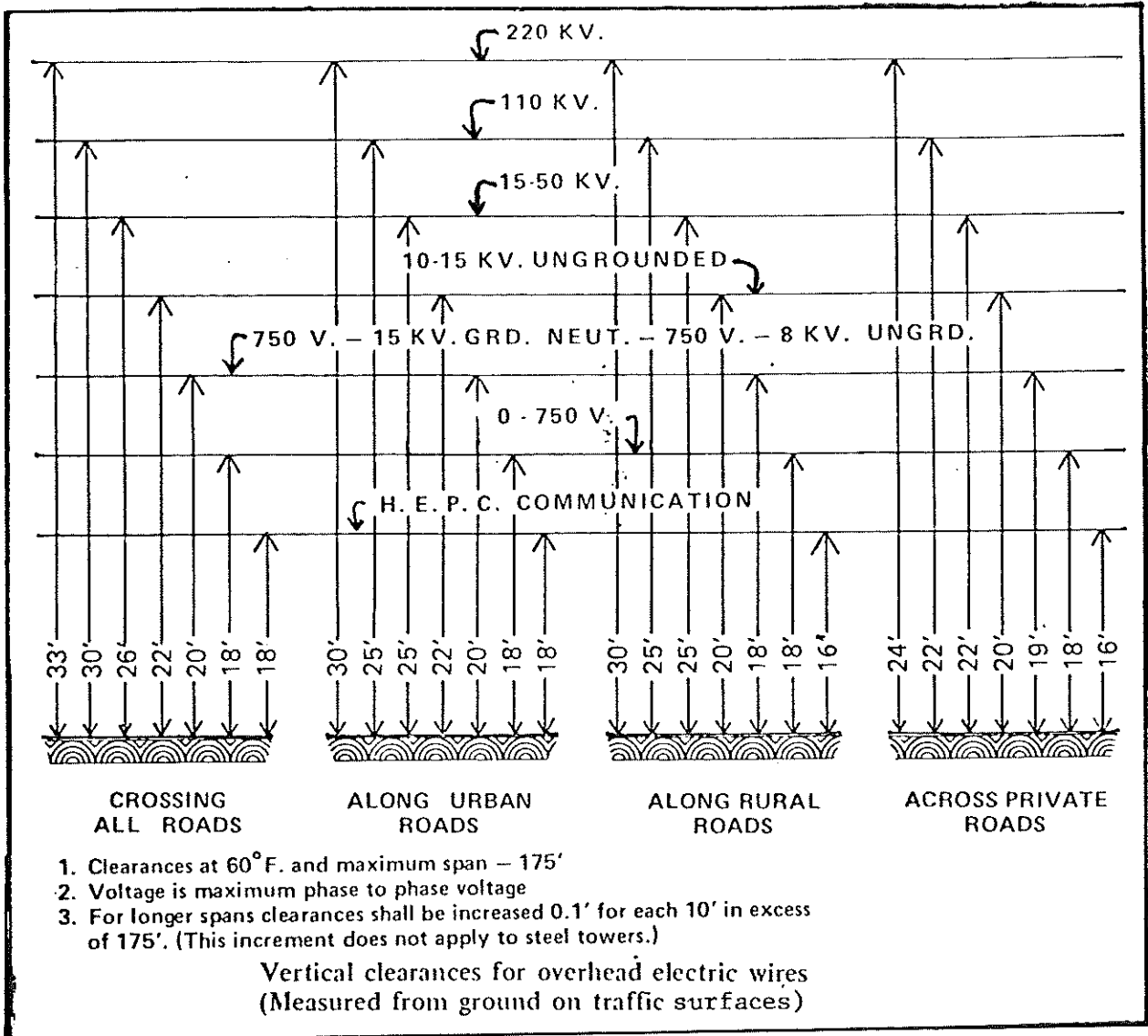

	Standard U-6.4	Polk County
	Overhead Utility Clearances.	
Effective	Rec'd 8/14/78	<i>Dale J. Harrington</i> Asst. Co. Engr.
	Approved 8/15/78	<i>R. E. Van Dine</i> Polk Co. Engr. P.E. No.

Ch. 7 SAW CUTS IN CONCRETE, ASPHALT, AND SEAL COAT STREETS

See Standard U-7.1

7.1 CONCRETE STREETS

- A. Saw cuts must be a minimum of 2" deep.
- B. Openings of concrete streets must be 9" larger than cut or trench excavation. See Detailed Standard
- C. Cuts must parallel and at 90° to the roadway.

7.2 ASPHALT CONCRETE STREETS

Same as 8.1

7.3 SEAL COAT STREET CUTS AND TRENCHES

- A. Cuts must be neatly cut with vertical opening.

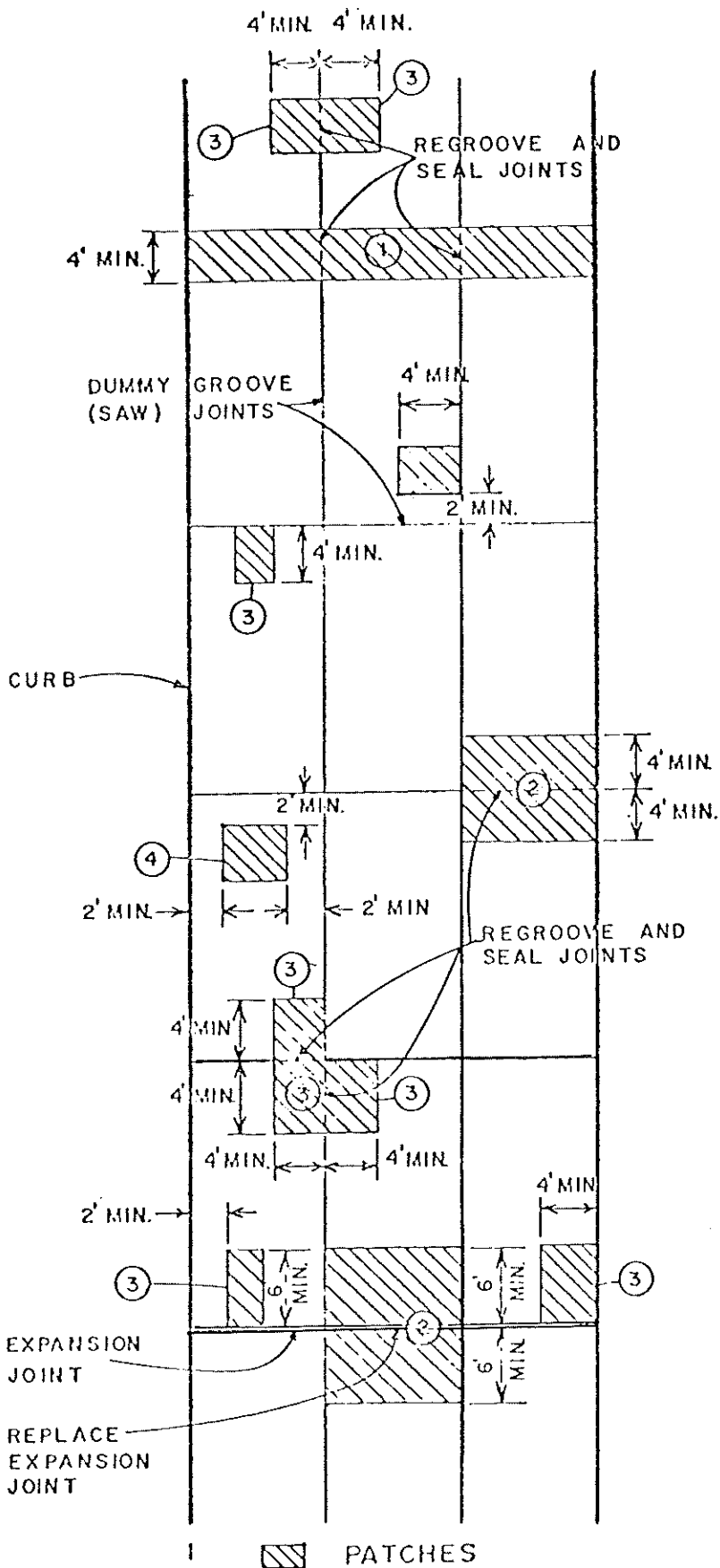

TYPICAL PATCH LOCATIONS FOR P.C.C. PAVEMENT

1. Full Width Patch - Extends all the way across the pavement. Joints that run across the street and lying in the patch, need not be replaced. If the patch is within 2 feet of a joint, the patch shall be extended to the joint. If the joint is replaced, the patch shall extend at least 6 feet on both sides of an expansion joint and 4 feet for other joints.
2. Single Lane Patches - Extends across one lane of pavement. All joints lying in the patch shall be replaced in their original location.
3. Edge Patch - Extends to a joint or the edge of the pavement. It shall extend at least 6 feet from an expansion joint and at least 4 feet from other joints.
4. Interior Patch - Must be at least 2 feet from a joint or pavement edge. If closer than 2 feet, it shall be extended to the joint or pavement edge and become an edge patch.
5. All patches must have a light broom finish against the flow of traffic.

Note: All patches shall be edged and sealed on all sides.

	Standard U-7.1	Polk County
	Saw Cuts in Paved Roadways	
Effective	Rec'd 8/14/78	<i>Dale S. Huntington</i> Asst. Co. Engr.
	Approved 8/15/78	<i>R. E. ...</i> Polk Co. Engr. P.E. No.

Ch. 8 UTILITY EXCAVATION

All provisions of the utility permit shall be a part of this section. Trench widths and depths shall be as designated on the detail standard for the type of bedding used.

8.1 TRENCH EXCAVATION

See Standards U-9.1 & U-9.2

LIMITS - The length of the trench to be opened, or the area of surface to be disturbed or uncovered at any time, shall be limited by the Engineer. All trenches shall be backfilled as soon as practical after the pipe is in place, but should be opened and closed the same day. New trenches shall not be excavated when open trenches have been ordered backfilled by the Engineer. All restoration in the streets shall be completed as the project progresses. In the event the contractor fails to complete such restoration, the Engineer shall not permit the contractor to open any additional trenches.

Trenches should be cut to vertical faces, where soil and depth conditions permit, with a maximum width of outside diameter of pipe plus two (2) feet and a minimum width of outside diameter of pipe plus fifteen (15) inches except for those utilities 5" or less in diameter that are installed by a plow or auger trencher in which the trench width shall not exceed 8". If trench widths exceed the maximum limits, higher class bedding and/or stronger pipe adequate to support backfill loads must be used subject to the Engineer's approval.

Pavements shall be removed to a minimum of one (1) foot outside the trench opening with no undercutting. Concrete paving and asphalt pavement shall be cut with a concrete saw. Seal coat and gravel surfaces may be removed with suitable excavating machinery.

Where jacking or boring is used to cross under a roadway, the working trench shall be no nearer the curb line or edge of pavement than two (2) feet. Excavate by hand under and around existing utilities.

8.2 UNCLASSIFIED EXCAVATION

Unless otherwise set forth in the proposal, all excavation for sewer, culvert, and incidental ditch construction shall be considered as unclassified excavation. This excavation shall include the removal of any and all materials necessary for the construction of the trench or ditch. Excavated material which is suitable for backfill shall be stockpiled along the trench, or in such a location as is suitable to the contractor and the Engineer. All excess material, and materials unsuitable for backfill, shall be removed from the site as directed by the Engineer.

8.3 EXCAVATION FOR STRUCTURES AND APPURTENANCES

- A. Includes excavation for manholes and other appurtenances.
- B. Excavate as required to firm undisturbed soil; if excavation is carried below bottom of foundation as shown on plans, fill with concrete or stabilizing material as directed at no expense to the owner.
- C. When unstable material is encountered which will not provide suitable foundation, fill with Class B concrete or stabilizing material specified hereinafter, as directed.
- D. Provide bell holes at each pipe joint; allow access completely around circumference of pipe for proper jointing operations.

8.4 ROCK EXCAVATION

If rock, shale, or similar material is encountered in the process of excavation, such rock shall be removed to a depth of not less than six (6) inches below the bottom of the pipe, and the trench shall be refilled with bedding aggregate. Rock excavation shall be completed well in advance. Not less than fifty (50) feet of sewer trench shall precede the laying of pipe.

8.5 QUICKSAND

Quicksand shall be removed and/or stabilized in order to provide a proper foundation for the sewer pipe.

8.6 PAVING REMOVAL

All pavements shall be cut with a saw. See Sec. 7.1

8.7 EXCAVATE BY HAND

- A. Under and around existing utilities.
- B. Where overhead clearance prevents use of machine.
- C. Under trees and shrubs where shown on plans.
- D. If removal of unsuitable material is authorized, replace with trench stabilizing material. See Standard U-9.1 and 9.2

8.8 DISPOSAL OF MATERIAL

The excavated material from the construction shall be placed compactly along the sides of the excavation, and kept so as not to endanger the work, and be of as little inconvenience as possible to the public travel and abutting property. Free access shall be provided at all times to

fire hydrants and water gates in the vicinity of the work, and fire fighting equipment shall be provided access to within three hundred (300) feet of any structure at all times. The contractor shall keep pedestrian walks open at all times.

8.9 ENCROACHMENT ON PRIVATE PROPERTY

Except when easements have been obtained, the contractor must obtain permission of property owners in writing, before depositing any material on private property. A copy of this written permission shall be filed with the Engineer. Salvageable materials and excess earth from this construction shall be disposed of by the contractor in such a manner acceptable to the Engineer. In all cases the contractor shall assume full liability for encroachment upon private property and shall assume full liability for any damages which occur as a result thereof.

8.10 DEWATERING

It is the intent of these specifications that the construction work herein contemplated shall be carried out under dry conditions. The contractor shall promptly and continuously dispose of all water from any source, that may accumulate in the excavation. This shall include all necessary pumping, well points, bailing, and draining. The excavation shall be kept dry until the entire invert is formed, and the joints and/or concrete becomes set, or until permission is given by the Engineer to allow water to pass over the work. The contractor shall provide dams, embankments, open channels, or other means necessary to keep the trenches clear of surface drainage while the work is in progress. The sewer shall not be used for the purpose of draining away water, except upon written permission from the Engineer for each occasion.

8.11 SHEETING AND SHORING

A. DESCRIPTION

When the material to be excavated is unstable, or the bottom of the trench will not hold its form when excavated, tight sheeting shall be used and shall be driven to a depth necessary to control the action of the bottom. The Engineer may approve the use of a sandbox in lieu of, or in conjunction with sheeting if, in his opinion, such use is warranted. Banks more than four (4) feet high must be shored or sloped to the angle of repose. Sides of trenches in unstable or soft material, four (4) feet or more in depth, must be shored, sheeted, braced, or sloped to protect employees working the trench. Ladders must be provided at not more than fifty (50) foot spacing in trenches three (5) feet or more in depth. Cross

bracing of trenches must be truly horizontal. Portable trench boxes for the protection of employees may be used. Trench shoring requirements are detailed in the Federal Construction Safety Act and the Occupational Safety and Health Act of 1970.

B. REQUIREMENTS

The contractor shall furnish and place such sheeting, sheet piling, planking, bracing, etc., as may be required to support the sides of the excavation. This support shall prevent any movement which would in any way injure the sewer or adjacent property, private or public utilities, diminish the width necessary for proper construction procedures, or otherwise injure or delay the work. The contractor shall assume all liability for any and all damages to property, or injury to workmen or other persons, which occur if sheeting is not used.

C. SHEETING LEFT IN PLACE

When, at the order of the Engineer, sheeting is to be left in place, for any reason, it shall be so directed in writing. Sheeting left in place shall be cut off at a height designated by the Engineer.

D. SHEETING REMOVAL

As the trench is refilled, and where no written order has been given to leave sheeting in place, the sheeting, bracing, etc. shall be removed in such a manner as to prevent the caving of the sides of the trench. While the sheeting and bracing are being withdrawn, the voids left by their withdrawal shall be carefully refilled and compacted by such methods as are approved by the Engineer.

E. PROTECTION OF UTILITIES

All utilities, through which service must be maintained during construction, shall be adequately supported and shall be the responsibility of the contractor.

Ch. 9 BEDDING AND FOUNDATION FOR UTILITIES - PIPE ENVELOPE

(Normally does not include singleline utilities 5"Ø or less that are installed by plow or auger trencher or singleline utilities 12'Ø or less that are installed in ditches, fore-slopes and backslopes. See Standard U-9.1 and U-9.2.

9.1 NORMAL

The contractor shall excavate below the bottom of the pipe to the depth as shown on the detail for the type of bedding called for. The contractor shall refill the space between the excavated bottom and the aligned pipe, up to the spring-line, with a bedding material as specified below. This bedding shall be placed and consolidated so as to provide a firm contact to all portions of the pipe below the spring-line.

9.2 BEDDING AGGREGATES

Normal bedding for Dry Trench conditions shall consist of natural sand or gravel. Aggregates shall be free from deleterious substances in amounts which the Engineer may determine as being excessive. In this determination, the Engineer will give consideration to the purpose for which the aggregates is intended. These aggregates shall be well graded and 100% by weight passing the No. 4 sieve with a maximum of 5% passing the No. 100 sieve. In Wet Trench conditions crushed stone or gravel not exceeding one (1) inch diameter shall be used as normal bedding.

9.3 ROCK

Where the bottom of the trench is unexpected rock, shale, or an equally unyielding material, such material shall be removed by the contractor to the depth shown in Standard U-9.1 & U-9.2 for the type of bedding required.

9.4 CONCRETE ENCASEMENT

Where indicated on the plans, concrete encasement shall be placed. Concrete used shall conform to Class "C" concrete according to the 1977 IDOT Specification. The concrete encasement shall be of the shape and cross-sections as shown on the detail plates. When required, reinforcement steel shall be placed in accordance with detailed plans.

9.5 FOUNDATION

When the material encountered in the bottom of the trench, in the judgment of the Engineer, is excessively wet or unstable, and a satisfactory firm uniform bearing surface for the pipe is not obtainable, the excavation shall be deepened sufficiently to allow the placing of an adequate amount of bedding material as shown in Standard U-9.1 & U-9.2 for the type of bedding required.

9.6 CONCRETE CRADLE

When required, a concrete cradle shall be used.

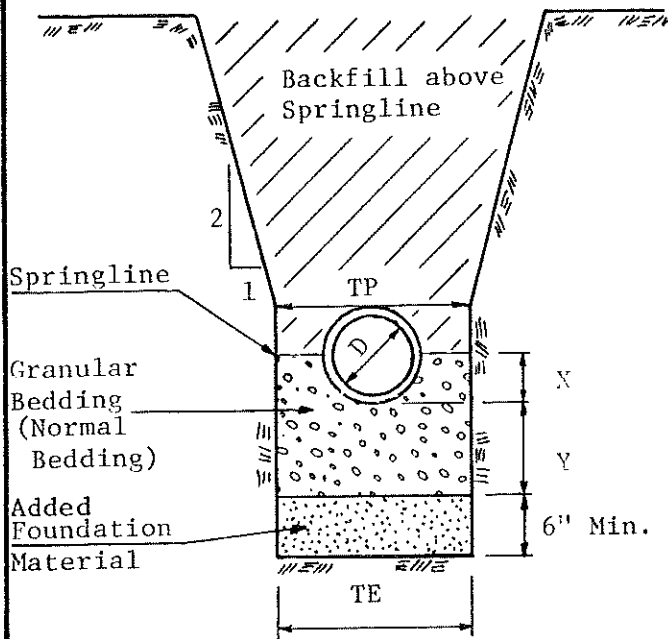

TE not to exceed TP Max.

** D Inches	TP FEET & Inches	X Inches	Y Inches
6	2-0	3	4
8	2-3	3	4
10	2-3	4	4
12	2-3	5	4
15	2-9	6	4
18	3-0	7	5
21	3-3	8	6
24	3-6	9	6
27	4-0	10	7
30	4-3	11	8
36	4-9	13	9

1. Backfill above Springline.
Backfill will conform to the following standards depending on the type of roadway and shoulder.
 - a. Standard U-10.1 & U-10.2
2. TP = Trench width @ top of utility pipe or springline.
3. TE = Trench width @ bottom of excavation.
4. Granular Bedding.
 - a. Dry Trench - 100% by weight passing the No. 4 sieve with a maximum of 5% passing the No. 100 sieve.
 - b. Wet Trench - Crushed stone or gravel not exceeding one (1) inch diameter.
5. Foundation Material - When foundation material is unsuitable, i.e., rock, quicksand, peat, muck, the material will be removed to a depth of 6" minimum and backfill with same material as used for granular bedding.

**D. When trenching is allowed by the Engineer for utility pipes or lines less than or equal to 5" diameter (in the shoulder only) the following will be adhered to:

- a. Diameter 3/8" to 2" - Trench plowing will be allowed.
- b. Diameter 2" to 5" - Trenching auger machine will be used with the trench width (TP) not to exceed 8" in width.
- c. Backfill for (a) and (b) will be selected, finely divided excavated material found in the same area and free from debris, stones, organic matter or frozen lumps and carefully compacted in 6" layers. See Section 10.3 for backfill requirements and Standard U-10.1 & U-10.2 for details.

	Standard U-9.1	Polk County
	Class A Bedding for Utilities under roadway, includes shoulders.	
Effective	Rec'd 8/14/78	<i>Robert J. Harrington</i> Asst. Co. Engr.
	Approved 8/15/78	<i>R. E. Van Dine</i> Polk Co. Engr. P.E. No.

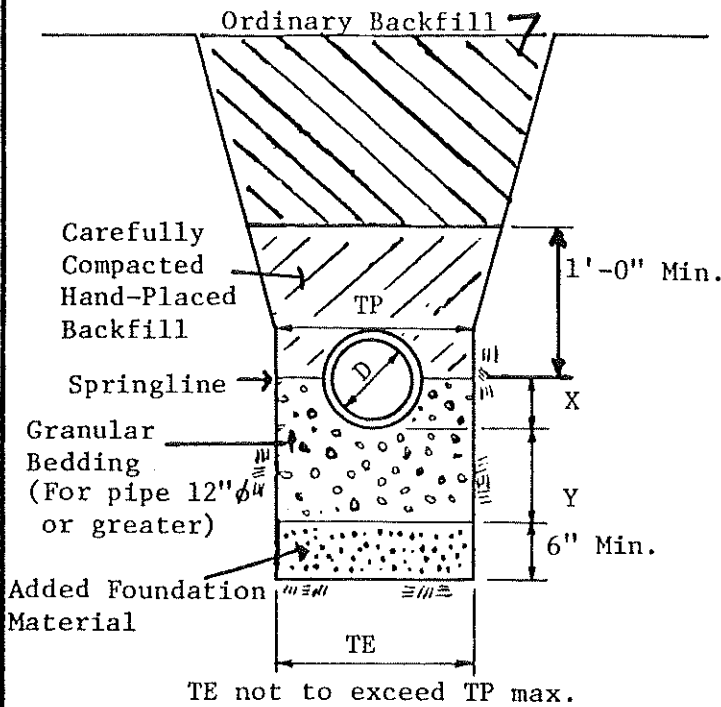

Notes:

1. Ordinary Backfill - See Standard 10.2 for backfill. All backfill material will be free from debris, stones, organic matter or frozen lumps and carefully compacted.
 2. Hand-placed backfill shall be selected, finely-divided excavated material free from debris, stones, organic matter or frozen lumps and carefully compacted in 6" layers to 85% proctor.
 3. TP = Trench width at top of utility pipe or line.
 4. TE = Trench width at bottom of excavation
 5. Granular Bedding.
 - a. Dry Trench - 100% by weight passing the No. 4 sieve with a maximum of 5% passing the No. 100 sieve.
 - b. Wet Trench - Crushed stone or gravel not exceeding one (1) inch diameter.
 6. Foundation Material - When foundation material is unsuitable, i.e., rock, quicksand, peat, muck, i.e., the material will be removed to a depth of 6" minimum and backfill with same material as used for granular bedding.
- *D. When diameter of utility pipe or line is 3/8" to 1", the trench may be plowed. Entire backfill will conform to "ordinary backfill." When diameter of utility is 2" to 5", a trenching machine may be used with the trench width (TP) not be exceed 8" in width. Entire backfill will conform to "ordinary backfill." When diameter of utility is 5" to 12", normal trenching methods will be used. Backfill will conform "hand-placed backfill" and "ordinary backfill."

Diameter of Utility Pipe or Line *D Inches	TP Feet & Inches	X Inches	Y Inches
4	2-0	1	0
6	2-0	1	0
8	2-3	1½	0
10	2-3	2	0
12	2-3	2½	4
15	2-9	3	4
18	3-0	3½	5
21	3-3	4	6
24	3-6	4½	6
27	4-0	5	7
30	4-3	5½	8
36	4-9	6½	9

	Standard U-9,2	Polk County
	Class B Bedding for Utilities outside of roadway, includes ditches, foreslopes & backslopes,	
Effective	Rec'd 8/14/78	<i>Walter S. Harrington</i> Asst. Co. Engr.
	Approved 8/15/78	<i>R. E. ...</i> Polk Co. Engr. P.E. No.

Ch. 10 BACKFILL AND COMPACTION

All cavities caused by utility construction operations inside the prescribed bed limits of the trench shall be completely filled with a density compacted material as herein specified. Regardless of the location of the trench, any cavities, exposed pavement, settlement, etc. that occurs after backfilling has been completed shall be refilled and compacted by the applicant in accordance with Ch. 319 of the Code of Iowa.

If, however, hazardous conditions exist to the traveling public as determined by the Engineer due to uncompleted work by the applicant, Polk County and/or a contractor employed by Polk County may make repairs at the applicant's expense. These repairs will be made after a two-hour notice to applicant if the applicant does not respond in that period of time.

10.1 TRENCH BACKFILL IN ROADWAY

Includes shoulders above springline (trench width greater than 8 inches).

A. Paved surfaces, asphalt concrete, Portland cement concrete, and A.C. resurfaced roadway. See Standard for details.

1. April 1 to November 15

- a. After granular bedding is installed up to the springline, then select backfill material consisting of sand, sandy clay, gravel or crushed stone (top size 1"), loam, or river run sand, containing no injurious silt, will be placed in 6" layers, up to two (2) feet below the pavement or shoulder. This material will be compacted to 85% proctor by mechanical or pneumatic tampers.
- b. The remaining 2' of backfill below the pavement will be select material as stated in (a) above and will be placed in 6" layers. This material will be compacted to 95% proctor by mechanical or pneumatic tampers.
- c. The depth of pavement will be replaced according to Standard U-10.1

2. November 15 to April 1 (Winter Construction)

- a. After granular bedding is installed up to the springline, then select backfill material consisting of sand or crushed rock, not exceeding 1" diameter, will be placed in 6"

layers up to two (2) feet below the pavement or shoulder. This material will be compacted to 85% proctor by mechanical or pneumatic tampers. No frozen material will be allowed in the backfill and all excavated material, not meeting the above requirements, will be wasted by the contractor at the direction of the Engineer.

- b. The remaining 2' of backfill below the pavement will be select material consisting of crushed rock, not exceeding 1" diameter, and will be placed in 6" layers, compacted to 95% proctor by mechanical or pneumatic tampers. No frozen material will be allowed in the backfill.
- c. The depth of pavement will be replaced according to Standard U-10.1

B. Seal coat, gravel or rocked roadways, and shoulders. See Standard U-10.2 for details.

1. April 15 to November 15

a. After granular bedding is installed up to the springline, then select backfill material consisting of sand, sandy clay, gravel or crushed stone (top size 1"), loam, or river run sand, containing no injurious silt, will be placed in 6" layers, up to two (2) feet below the pavement or shoulder. This material will be compacted to 85% proctor by mechanical or pneumatic tampers.

b. The remaining 2' of backfill below the seal coat pavement or gradeline of the gravel, rock, and shoulder will be 1' of select backfill, as stated in (a) above, and then 1' of crushed stone, not to exceed 1" in diameter, will be placed in 6" layers, compacted to 95% proctor by mechanical or pneumatic tampers.

c. The depth of pavement will be placed according to Standard U-10.2

2. November 15 to April 1 (Winter Construction). Under normal conditions, trenching will not be allowed when the roadway surface is frozen to a depth greater than 2.0 feet.

a. After granular bedding is installed up to the springline, then select backfill material consisting of sand or crushed rock, not exceeding 1" diameter, will be placed in 6" layers up to two (2) feet below the pavement or shoulder. This material will be compacted to 85% proctor by mechanical or pneumatic tampers. No frozen material will be allowed in the backfill and all excavated material, not meeting the above requirements, will be wasted by the contractor at the direction of the Engineer.

- b. The remaining 2' of backfill below the pavement will be select material consisting of crushed rock, not exceeding 1" diameter, and will be placed in 6" layers, compacted to 95% proctor by mechanical or pneumatic tampers. No frozen material will be allowed in the backfill.
- c. The depth of pavement will be placed according to Standard U-10.2

10.2 TRENCH WIDTH GREATER THAN 8" BACKFILL OUTSIDE OF ROADWAY

Located in ditches, foreslopes, and backslopes.

- A. Utility pipe 12"Ø or less (except sanitary sewer).

For pipes up to and including 12" diameter, except sanitary sewers, shape bottom of trench to provide uniform and continuous support of the pipe over its entire length on firm stable material. Hand excavate for pipe bell. Place backfill and compact 90% proctor to one (1) foot above top of pipe in 6" maximum lifts. All material will be free from debris, stones, organic matter, or frozen lumps.

- B. Utility pipe 12"Ø or greater and all sanitary sewers.

After granular bedding is installed up to the springline, then select backfill consisting of finely divided excavated material free from debris, stones, organic matter, or frozen lumps will be placed in 6" layers for depth of one (1) foot. This material will be compacted to 85% proctor by mechanical or pneumatic tampers.

- C. Remaining fill above pipe.

The remaining "Ordinary" backfill material will consist of excavated material free from debris, stones, organic matter, or frozen lumps and will be placed in 1' layers. This backfill will be well compacted by hydraulic or mechanical equipment.

10.3 TRENCH WIDTH EQUAL TO OR LESS THAN 8" IN WIDTH

- A. Gravel, rock roadways, and shoulders.

When plowing or auger trenching is allowed by the Engineer for utility pipes or lines less than or equal to 5" diameter, the backfill shall consist of finely divided excavated material found in the same area and free from debris, stones, organic material, or frozen lumps and carefully compacted in 6" layers. The top one (1) foot will be compacted to 95% proctor by mechanical or pneumatic tampers.

- B. Ditches, foreslopes, and backslopes.

When plowing or trenching is allowed by the Engineer for utility pipes or lines less than or equal to 5" diameter, the backfill will be finely divided excavated material found in the same area and free from debris, stones, organic material, or frozen lumps and carefully compacted in one (1) foot layers.

GENERAL NOTES:

I. Backfill and Compaction.

- A. All cavities caused by utility construction operations inside the prescribed bed limits of the trench shall be completely filled with a density compacted material as herein specified. Regardless of the location of the trench, any cavities, exposed pavement, settlement, etc. that occurs after backfilling has been completed shall be refilled and compacted.

II. Construction Periods.

- A. April 1 to November 15.

1. After granular bedding is installed up to the springline, then select backfill material consisting of sand, sandy clay, gravel or crushed stone (top size 1"), loam, or river run sand containing no injurious silt will be placed in 6" layers, up to two (2) feet below the pavement or shoulder. This material will be compacted to 85% proctor by mechanical or pneumatic tampers. All excavated material not conforming will be wasted by the contractor.

2. The remaining 2' of backfill below the pavement will be select material as stated in (1) above, and will be placed in 6" layers. This material will be compacted to 95% proctor by mechanical or pneumatic tampers.

- B. November 15 to April 1 (Winter Construction).

1. After granular bedding is installed up to the springline, then select backfill material consisting of sand or crushed rock not exceeding 1" diameter, will be placed in 6" layers, up to two (2) feet below the pavement or shoulder. This material will be compacted to 85%

April 15 to November 15: Surface Coarse will be 2" Min. Type "B" Asphaltic Concrete Surface.

November 15 to April 15: Eliminate 2" A.C. Surface and Construct 10" Total P.C. Concrete Depth Using M-4 Mix.

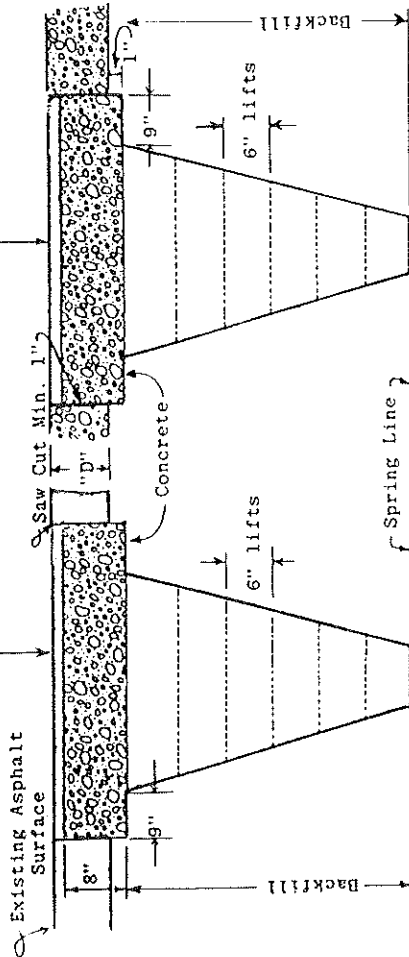

ASPHALTIC RESURFACING OF ASPHALTIC CONCRETE PAVEMENT

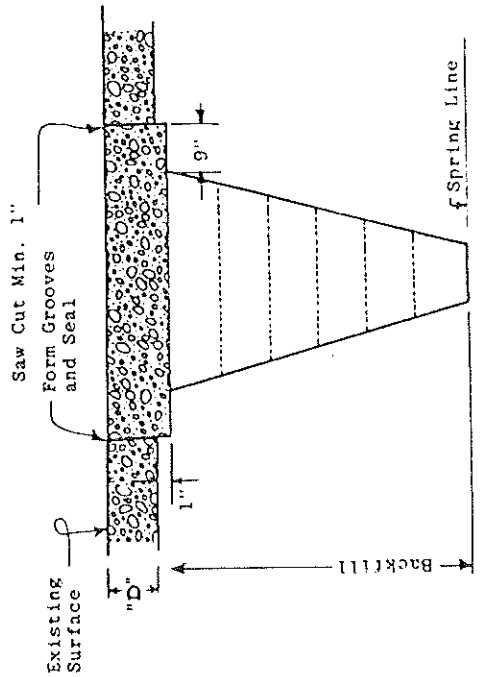

P.C.C. PAVEMENT

proctor by mechanical or pneumatic tampers. No frozen material will be allowed in the backfill and all excavated material, not meeting the above requirements, will be wasted by the contractor at the direction of the Engineer.

2. The remaining 2' of backfill below the pavement will be select material consisting of crushed rock, not exceeding 1" diameter, and will be placed in 6" layers, compacted to 95% proctor by mechanical or pneumatic tampers. No frozen material will be allowed in the backfill.

III. Normal concrete shall be 4000 psi Class "A" concrete - April 1 to November 15.

IV. "M-4" concrete will be allowed between November 15 and April 1. The minimum depth of concrete for this time period is 10". For "M-4" a 1/4" radius edge will be required around all end areas.

V. Edges of all openings on pavement shall be saved. After concrete is in place a 1" saw joint will be required at the face with existing concrete pavement.

Standard U-10.1	Polk County
Backfill and Pavement Replacement in Roadway Above Springline (Trench Width Greater Than 4')	
Rec'd	8/9/78
ASST. CO. ENGR.	<i>[Signature]</i>
Approval	8/11/79
Effective	Polk Co., Engr., P. E. 30

April 15 to November 15: 6" Min. Depth Type "B" A.C. Base or Better.
 November 15 to April 15: 10" Min. Depth - M-4 P.C. Concrete.

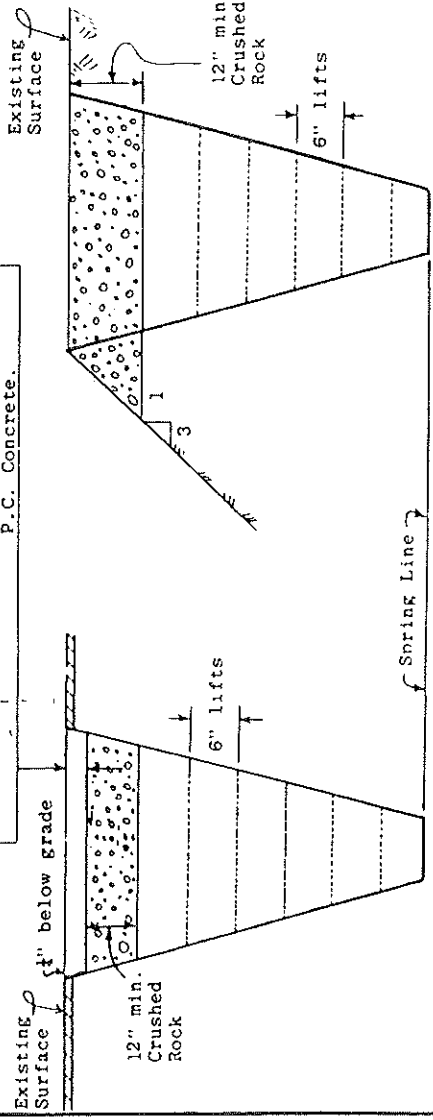

GRAVEL, ROCK, OR DIRT STREETS, AND SHOULDERS

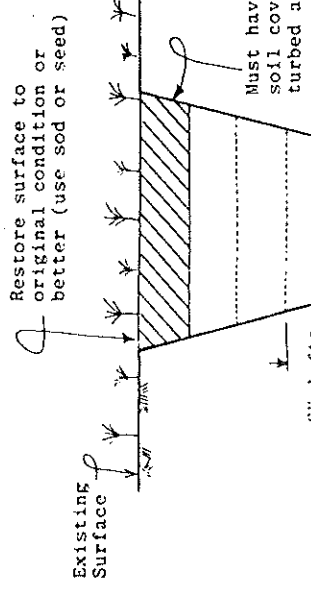

FORESLOPES, BACKSLOPES, AND DITCHES

GENERAL NOTES:

- I. Backfill and Compaction for Seal Coat, Gravel, or Rocked Roadways and Shoulders with Trench Width Greater than 8".
 - A. April 15 to November 15.
 1. After granular bedding is installed up to the springline, then select backfill material consisting of sand, sandy clay, gravel, or crushed stone (top size 1"), loam, or river run sand, containing no injurious silt, will be placed in 6" layers up to two (2) feet below the pavement or shoulder. This material will be compacted to 85% proctor by mechanical or pneumatic tampers.
 2. The remaining 2' of backfill below the seal coat pavement or grade-line of the gravel, rock, and shoulder will be 1' of select backfill as stated in (1) above, and then 1' of crushed rock, not to exceed 1" in diameter, will be placed in 6" layers and compacted to 95% proctor by mechanical or pneumatic tampers.
 - B. November 15 to April 1 (Winter Construction).
 1. After granular bedding is installed up to the springline, then select backfill material consisting of sand or crushed rock, not exceeding 1" diameter, will be placed in 6" layers, up to two (2) feet below the pavement or shoulder. This material will be compacted to 85% proctor by mechanical or pneumatic tampers. No frozen material will be allowed in the backfill and all excavated material not meeting the above requirements will be wasted by the contractor at the direction of the Engineer.
 2. Same as I - A - 2.
- II. Pavement Replacement for Seal Coat.
 - A. Normal concrete shall be 4000 psi Class "A" concrete - April 1 to November 15.
 - B. "M-4" concrete will be allowed between November 15 and April 1. The minimum depth of concrete for this time period is 10". For "M-4" a 1/4" radius edge will be required around all end areas.
- III. Backfill and Compaction for Trench Width Greater Than 8" Backfill Outside of Roadway. Includes Ditches, Form-slopes, and Backslopes. (See Sec. 10.)
 - A. Select backfill consisting of finely divided excavated material free from debris, stones, organic matter, or frozen lumps will be placed in 6" layers for depth of one (1) foot. This material will be compacted to 85% proctor by mechanical or pneumatic tampers.
 - B. The remaining "ordinary" backfill material will consist of excavated material free from debris, stones, organic matter, or frozen lumps and will be placed in 1' layers. This backfill will be well compacted by hydraulic or mechanical equipment.
- IV. Backfill and Compaction for Trench Width 8" or Less. (Sec. 10.3)
 - A. Gravel, rock roadways, and shoulders.
 1. When plowing or auger trenching is allowed by the Engineer for utility pipes or lines less than or equal to 5" diameter, the backfill shall consist of finely divided excavated material found in the same area and free from debris, stones, organic material, or frozen lumps and carefully compacted in 6" layers. The top one (1) foot will be compacted to 95% proctor by mechanical or pneumatic tampers.
 - B. Ditches, foreslopes, and back-slopes.
 1. When plowing or trenching is allowed by the Engineer for utility pipes or lines less than or equal to 5" diameter, the backfill will be finely divided excavated material found in the same area and free from debris, stones, organic material, or frozen lumps and carefully compacted in one (1) foot layers.

Standard II-10.2	Polk County
Backfill and Surface Replacement Above Springline for Seal Coat & Gravel, Roadways, and Ditches.	
Rec'd 8/9/78	Dale H. Hensley
Approved 9/11/78	Asst. Co. Engr.
Effective	Polk Co. Engr. P.E. J.D.

Ch. 11 UNTRENCHED UTILITY

When untrenched construction techniques are utilized the bore shall be as small as possible and in no case more than 4" in diameter larger than the facility or casing inserted. Grout or sand backfill is required for unused holes, for abandoned pipes over 3" in diameter. Backfill is also required for bore holes in excess of 2" oversize in diameter of the facility or casing inserted.

The untrenched installation of a utility will be required under all paved roadways, driveways, sidewalks, and railroads. Untrenched installation of utilities will also be required under gravel roadways when the top ground surface is frozen. If a water main exists in the roadway, trenching will be allowed only when the method is approved by the Engineer.

The untrenched operation shall be carried on without encroachment upon the roadway by either the excavation or by the storage of equipment or materials. Suitable warning signs and lights shall be furnished and maintained by the contractor. When open cut excavation encroaches upon the shoulder, at the approval of the Engineer, the excavation shall be protected with substantial barricades. On railways, the restrictions and safety regulations of the railway company shall be observed. When open cut excavation is permitted on the slope of the embankment outside the vertical planes that bound the traveled way, adequate sheeting and bracing shall be provided if the nature and condition of the soil or the height of the exposed faces is such as to endanger either the traveling public or the integrity of the road surfacing.

For sewer installations the vertical tolerance will be 0.2 or as to permit gravity flow and 2' horizontal.

11.1 AUGERING (BORING)

Under this item the Contractor shall install a utility, the specified diameter and type of carrier pipe in a steel casing of the type and thickness specified herein. The operation shall be carried on without encroachment upon the traveled way by either the excavation or by the storage of equipment or materials. Wet boring methods will not be allowed underneath roadway, structures, etc. with a water pressure greater than 35 psi or in sandy or silty soils.

11.2 PUSHING UTILITIES

(This applies only when the size of the utility is 5" diameter or smaller and the soils are of firm clay texture.)

A means of going through an embankment without augering or jacking, but by pushing or drilling the utility itself or a pushing tool through the embankment. When using a pushing tool, the pushing tool must not be larger than the utility to be installed. To install by the use of a pushing tool, attach the utility to the pushing tool and remove the pushing tool from the embankment, thereby installing the utility. The utility may require encasement. (See Chapter 12.)

11.3 TUNNEL EXCAVATION

The culvert, utility, or sewer may be constructed in a tunnel only when approved in writing by the Engineer. The method of tunnel construction shall at all times be subject to the approval of the Engineer. The approval of the Engineer of such construction shall not relieve the Contractor from full responsibility for the adequacy and safety of the construction. The tunnel shall be kept adequately and securely braced with timber. The Contractor shall be responsible for the prevention of the settlement of the surface above the tunnel during and after construction.

11.4 JACKING CARRIER PIPE

A. DESCRIPTION

Installation of pipe by jacking shall consist of furnishing and placing pipe of the size, type, and design shown on the plans or specified in the contract. This method of installation will be specified where maintenance of traffic on the existing road requires that the traveled way remain undisturbed or where, for other reasons, the installation of a utility or culvert by the "cut and cover method" is impractical or undesirable. This operation requires that the pipe, as a unit or in sections, be forced through the existing embankment from side to side by the application of force to the projecting end, the necessary excavation being performed by the removal of the excavated material through the pipe as it progresses.

B. MATERIALS

Pipe may be either single unit or sectional. If sectional, it shall have joints of a type that will assure positive engagement of the sections during the jacking process and subsequently thereto. Square end pipe without proper connecting devices will not be permitted. Pipe having projections on their exterior surfaces, such as to necessitate an excavation larger than the body of the pipe, will not be permitted.

C. ALIGNMENT

INITIAL - Before jacking is started, the pipe of the initial section thereof shall be carefully aligned on a prolongation of the line and grade shown on the plans or staked by the Engineer, and shall be so held by braces, guideways and other devices as to deviate from those lines and grades as little as possible as it progresses through the embankment.

D. DURING JACKING

The alignment and elevation of the forward end of the pipe shall be kept under control throughout its passage through the embankment. Accumulated errors which cause the forward end of the pipe to deviate from the specified grade by more than 0.5% shall be cause for rejection.

E. DEVIATIONS

In any case the deviation from the designated flow line elevation and location of the initial point shall not exceed one-tenth (0.1) foot. Deviation from the prescribed grade that reverses the fall of the grade line through the pipe shall be cause for rejection.

F. JACK PLACEMENT

The number of jacks used shall be such as to exert sufficient force to overcome the greatest resistance to be encountered, considering both weight of pipe and the friction on its exterior surface. Care shall be taken that the jacks and struts are so arranged against the backslope, or deadmen placed for the purpose that the thrust is applied with the center line of the pipe and distributed equally between jacks.

G. PRESSURE DISTRIBUTION

The pressure exerted by the jacks shall be applied uniformly over the end of the pipe by a collar or shall be distributed to a number of points around the perimeter by cross timbers. Application of pressure with the metal of the jack in direct contact with the material of the pipe will not be permitted with either concrete or corrugated metal pipe. Suitable cushioning material shall be inserted between the jack and pipe. Spalled concrete or crumpled metal, which will result in an unsatisfactory joint when the succeeding section of pipe is placed, shall be cause for the rejection and removal of the section so injured.

H. EXCAVATION

Excavation for a limited distance ahead of the forward end of the pipe will be permitted when the soil is sufficiently stable to stand without danger of caving. In this case, the hole shall be trimmed to the neat size of the outside of the pipe to reduce the resistance of jacking and to maintain contact between the embankment material and the outside surface of the pipe. In the case of soft or unstable soil, the pipe shall be allowed to cut its way through the soil to avoid danger of caving and subsidence of the overlying embankment and roadway.

12.1 ENCASEMENT - UNTRENCHED METHOD ONLY

- A. An encasement shall be an oversized load-bearing casing, conduit duct or gallery through which a carrier, cable, or pipe is inserted in order to protect the roadway from damage and to provide for repair, removal or replacement of the utility facility without interference to highway traffic.
- B. All utility carriers described below will require encasement under future or existing paved roadways, driveways, near footings of bridges or structures, across unstable or subsiding ground, railroads, trunk or higher designed roadways, and at locations where the minimum bury depth cannot be met or where there may exist a hazard to the general public or carrier.

Transmittant Requires encasements

Water-----In firm clay soils that would allow cone boring and 12"Ø or less may be permitted to cross highway right-of-way utilizing a high strength carrier pipe (ductile iron or C-900 plastic pipe) to replace the casing pipe. Should the soils be of sandy texture boring and concurrent encasement will be required for lines 2" to 12"Ø. All lines greater than 12"Ø will require encasement. Water lines 2"Ø or less will be copper.

Sewer-----All lines

Telephone-----All lines or group of lines that are greater than 5"Ø

Electric-----All lines or group of lines that are greater than 5"Ø

Gas-----In firm clay soils that would allow cone boring pipe lines 59 psi and under and less than 12"Ø may be permitted to cross highway right-of-way utilizing a high strength carrier pipe to replace the casing pipe. However, the carrier pipe must be designed in conformance with a.l carrier and casing criteria set forth herein and should employ a higher safety factor in design, construction and testing than would normally be required for cased construction. Regardless of pressure all gas carrier lines 12"Ø or greater will require dry augering and encasement according to criteria contained herein. In addition all carrier lines 4"Ø or greater will be steel. Should the soils be of sandy texture, boring and concurrent encasement will be required.

C. MATERIAL

All utility carriers that require encasement shall conform to the following materials. Steel casing shall be spirally welded or other approved steel pipe having a minimum yield point of 35,000 psi. The pipe shall be new and shall be painted inside with a shop coat of primer for metal conforming to AASHTO M229 Type II (FSS TT-P-615 Type II). The outside shall be bitumen coated. The following will be adhered to:

1. Conforms to ASTM SPEC. A-256 Grade Z or A-139 Grade B.
2. Pipe shall be new and straight without deformation.
3. The void filled with sand by blowing method or premanufactured casing. Two alternatives to sand fill between casing and carrier are:
 - a. Rigid insulation spacers preattached to the carrier pipe in such a manner that the transmittants do not escape through the spacer connections.
 - b. Modular link design (Link-seal) can be used as long as the span does not deflect more than 5 percent. If the carrier pipe deflects more than 5 percent, an intermediate sleeve may be required.
4. Casing shall be 4" diameter larger than the extreme outside diameter of the carrier pipe or coupling except where link seal is used in which the manufacturer's spacing will be followed.

OUTSIDE DIAMETER	WALL THICKNESS (INCHES)	
	UNDER HIGHWAY	UNDER RAILROAD
12 3/4" & under	0.188	0.250
16"	0.250	0.250
18"	0.250	0.312
20"	0.250	0.312
24"	0.250	0.375
30"	0.312	0.500

Concrete encasement will be allowed for multiway telephone or electric groupings.

D. CASING PIPE INSTALLATION

A casing pipe shall be installed using equipment which encases the hole as the earth is removed. High pressure wet boring or boring without the concurrent installation of a casing pipe will not be permitted. Casing shall extend continuously through the entire augered bored length and as a minimum, the augered or bored length will extend three (3) feet beyond the slope or ditch lines. On curbed sections, it should extend outside the outer curbs. All joints will be welded.

E. ALIGNMENT AND DEVIATION

The casing pipe shall be installed at such line and grade that the sewer which it encases can be installed at proper line and grade. A tolerance of 0.5% from design grade will be allowed. However, reversal of pitch is cause for rejection.

F. VENTS

If the casing is vented, the vents must be protected from the weather to prevent water from entering the casing. Vents should be as near the right-of-way line as possible.

G. BULKHEADS

If there is a possibility of water entering the casing, the ends must be sealed. Where casing does not extend for the entire run between manholes, the annular space between the culvert, utility or sewer, and casing shall be sealed with a Portland cement mortar bulkhead at the ends of the casing.

H. OBSTRUCTIONS

If the progress of the boring is stopped by an obstruction which will not allow completion of the conduit, the casing shall be withdrawn and the cavity filled with sand blown in.

12.2 UNENCASEMENT - TRENCH AND UNTRENCHED METHOD

- A. Under normal conditions the following utilities may be permitted to be placed uncased that are located under unpaved trunk collectors and local roads not proposed for seal coating or paving in the current Five-Year High Priority Secondary Road Program, if they do not constitute hazards and meet the requirements of April 15 to November 15 trenching. All unencased carrier pipe shall meet the applicable internal and external (roadway loads) strength requirements and soil conditions that could cause failure from frostboils.

Transmittant

Install Methods

	Trench Method	Untrenched Method
Water	Mechanical joint ductile iron bituminous coated carrier pipe no greater than 12"Ø or C-900 plastic pipe 2" to 12"Ø. For lines 2"Ø or small, copper pipe is required. All lines greater than 12"Ø will be encased.	All lines 12"Ø or less. Lines 2"Ø or less will be copper. Lines 2"Ø or greater will be same material as trench method.
Telephone	12"Ø or less Metal or plastic carriers that meet roadway dead & live load requirements & applicable safety codes. All lines greater than 12"Ø will be encased.	All lines or groups of lines 5"Ø or less and meet required roadway dead and live load requirements and applicable safety codes.
Electric	12"Ø or less Metal or plastic carriers that meet roadway dead & live load requirements & applicable safety codes. All lines greater than 12"Ø will be encased.	All lines or groups of lines 5"Ø or less and meet required roadway dead and live load requirements and applicable safety codes.
Gas	Pressure lines equal to or less than 59 psi and less than 12"Ø. See Ch. 12.1B	Pressure lines 59 psi or less and less than 12"Ø. See Ch. 12.1B

If a steel cutting edge is fitted to the forward end of the pipe, excavation may not be permitted beyond the plane of the cutting edge. If the pipe is of metal with a coating of corrosion-resisting material, care shall be taken to protect this coating from injury during the jacking and excavating process.

B. OBSTRUCTIONS

Obstructions to the progress of the pipe, such as roots, boulders, or parts of former structures shall be removed and deviations from line or grade to pass such obstructions shall be avoided, if such deviation will result in ill-fitting joints. The use of explosives for removing obstructions is prohibited.

